

ELECTRIC LIFT TRUCK OPERATOR'S MANUAL

75 SERIES

FB10P/14P/15P/18P

FB20P/25P/28P

FB30P/35PJ

【CAN-BUS SYSTEM】

APPLICABLE TRUCKS

FB10P/14P/15P/18P-75 : 221AE3656~

FB20P/25P/28P-75 : 241AC6266~

FB30P/35PJ-75 : 251AC0881~

▲ WARNING

Unsafe use of this lift truck may cause serious injury or death. Operators and maintenance personnel must read this manual and be sure that they understand its contents before operating, inspecting or carrying out maintenance on this lift truck. This manual should be kept near the lift truck for reference and periodically reviewed by all operators and maintenance personnel who come in contact with it.

**ELECTRIC
LIFT TRUCKS**

**OPERATOR'S
MANUAL**



NICHYU



INTRODUCTION



The operator must read and understand the instruction of safe operation contained in this manual.

- This operator's manual provides for the proper operation, easy maintenance and periodical inspection.
- Prior to operation, read this manual carefully for safe and efficient operation.
- Specifications and equipment in this manual are subject to change without any notice by the manufacturer for further improvement and modifications.
- Make sure these important instructions in this manual are available for the operator on each delivery or transfer of lift truck. Keep this manual after reading.
- If you have any questions, please feel free to contact your local NICHYU dealer.

 and  are very important for you and others for safety. Follow these instructions.

	DANGER	Indicates an extremely hazardous situation which, if not avoided, will result in death or serious injury. You must follow this instruction.
	WARNING	Indicates a potentially hazardous situation which, if not avoided, could result in death or serious injury. You must follow this instruction.
	CAUTION	Indicates a potentially hazardous situation which, if not avoided, may result in minor or moderate injury. You must follow this instruction.
	NOTE	Indicates suggestions, tips and hints related to the safety of an operator and maintenance of a truck.

CONTENTS

1 SAFE OPERATION	1	6 INSPECTION OF AFTER OPERATION	90
Decals and name plates	1	Inspection after working	90
Information for safety operation	5	7 PERIODIC SERVICING	91
How to survive in a tip over	18	Precautions of maintenance	91
2 PART NAME AND FUNCTION	19	Weekly (50-hour) servicing	94
Name of part	19	Monthly (200-hour) servicing	96
Driving equipment	19	Lubrication points and recommended oil	97
Indicator panel	20	Every three-month (600-hour) servicing	98
Indication of display	21	Semiannually (1200-hour) servicing	98
Function of display	22	Replacing parts and trouble shooting	99
Various kinds of mode selection	28	8 QUICK FAULT FINDING	101
Operating equipment	34	9 PERIODICAL REPLACING PARTS	102
Laser pointer (Option)	39	10 STABILITY OF FORKLIFT TRUCK	103
3 DRIVING AND OPERATION	44	Load center and load chart	103
Preparation of start	44	Stability of the forklift truck	104
Traveling	45	11 SPECIFICATIONS	105
Stacking operation	46	12 COLD STORAGE TYPE FORKLIFT TRUCK ..	108
Picking operation	47	Protection from rust and corrosion	109
How to use the laser pointer (Option)	49	Protection from low temperature	109
Picking operation of the load	49	13 SIDESHIFT ATTACHMENT	110
4 BATTERY AND CHARGER	51	FB series with side shift attachment	110
Battery	51	Safe operation	111
Precautions for charging the battery	54	Part name and function	112
Charger	56	Materials handling	113
How to charge the battery (By built-in charger)	58	Periodical inspection and service	116
How to charge the battery (By stationary charger)	73	Periodical replacing parts	118
Level of electrolyte and specific gravity	79	14 FINGER TIP LEVER	119
Exchanging battery	82	Operating Equipment	119
5 INSPECTION PRIOR TO OPERATION	85	Preparation to start	121
Check point and contents	85		
Inspection procedure	86		

To know about specification of forklift
11 SPECIFICATIONS [P105-]

- OPTIONS**
- LASER POINTER [P39-]
 - 12 COLD STORAGE TYPE FORKLIFT TRUCK [P108-]
 - 13 SIDE SHIFT ATTACHMENT [P110-]

To know about procedure of operation
2 PART NAME AND FUNCTION [P19-]

- 3 DRIVING AND OPERATION [P44-]

To know about periodical inspection and maintenance
7 PERIODIC SERVICING [P91-]

- 5 INSPECTION PRIOR TO OPERATION [P85-]

- 6 INSPECTION OF AFTER OPERATION [P90-]

- 9 PERIODICAL REPLACING PARTS [P102-]

To know about safe operation
1 SAFE OPERATION [P1-]

- 10 STABILITY OF FORKLIFT TRUCK [P103-]

To know about procedure of countermeasure for break down
8 QUICK FAULT FINDING [P101-]

To know about battery and charger
4 BATTERY AND CHARGER [P51-]

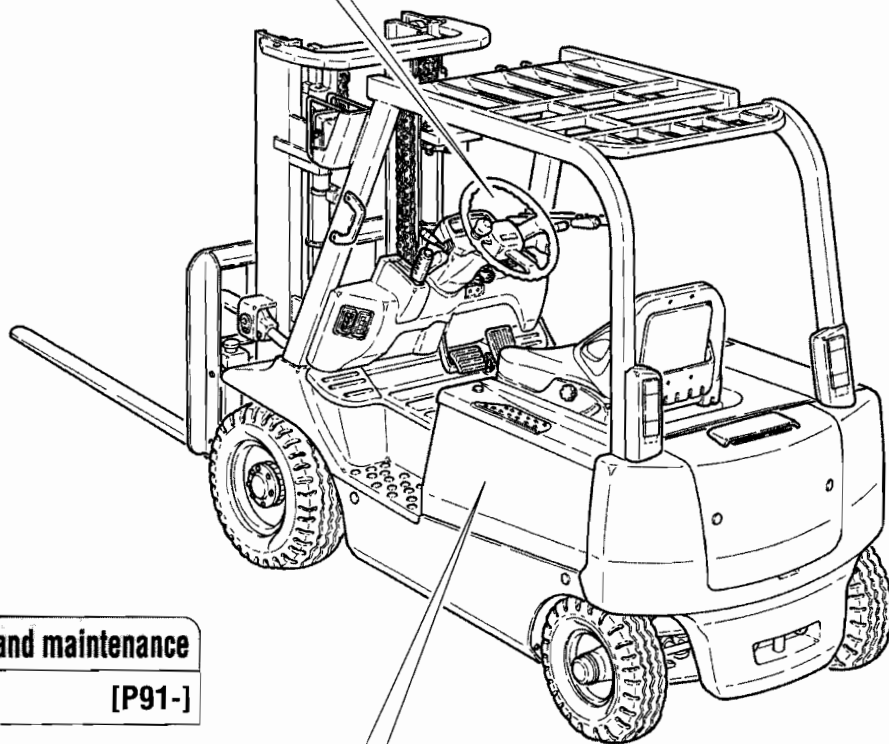

- 1
- 2
- 3
- 4
- 5
- 6
- 7
- 8
- 9
- 10
- 11
- 12
- 13

Decals and name plates



Decals and name plates are installed on the forklift truck to give information about possible hazards.



If you find that the decals and name plates are removed and/or unreadable, contact your local NICHYU dealer for replacement.

► Indication of direction (Right side / Left side)

The following illustration shows the direction of this forklift truck from the operator's compartment.

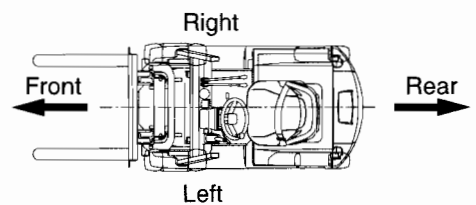

► Decals and Name Plates

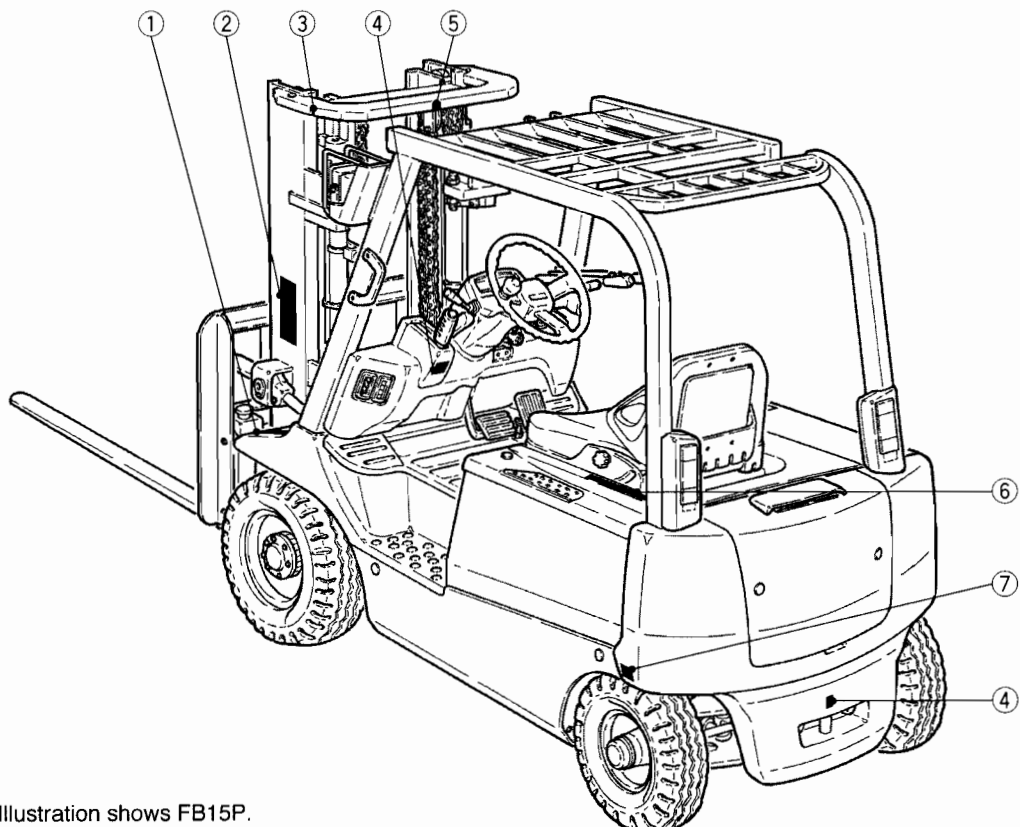
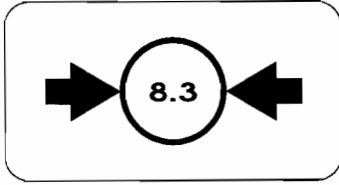

Illustration shows FB15P.

① (For CE)

(FB10P/14P)



(FB15P-28P)

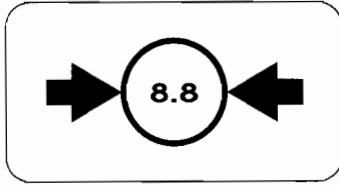

(FB30P)

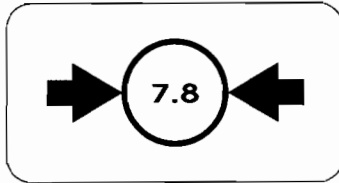

②

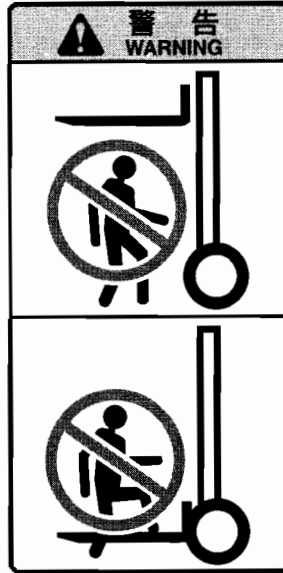

③

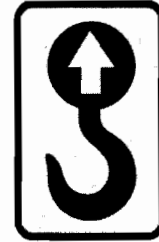

④

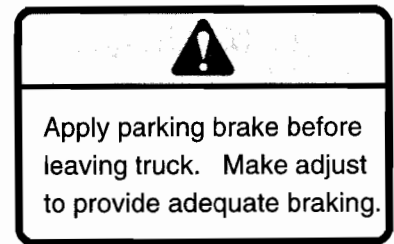

⑤



⑥



FOR SAFETY NOTICE FOLLOWING WARNINGS

1. Lateral tipover can occur when unloaded if the combination of speed and sharpness of turn produces an overturning moment which exceeds the stability of the truck.
2. Lateral tipover can occur if overloaded or loaded within capacity and the load is elevated and if turning and/or braking when traveling rearward or if turning and/or accelerating when traveling forward produces an overturning moment which exceeds the stability of the truck. Rearward tilt and/or off-center positioning of the load and/or uneven ground conditions will further aggravate the above conditions.
3. Longitudinal tipover can occur if overloaded or when loaded within capacity and the load is elevated if forward tilt, braking in forward travel, or commencing rearward travel produces an overturning moment which

exceeds the stability of the truck.

4. Serious injury or death can occur to the operator if he/she is trapped between the truck and the ground.

IN CASE OF TIPOVER

1. The operator should stay with the truck if lateral or longitudinal tipover occurs. The operator should hold on firmly and lean away from the point of impact.
2. The operator should stay with the truck if it falls off a loading dock or ramp. There are other situations where the environment of the landing area presents a severe hazard. In those incidents, it may be prudent for the operator to leave the truck.

24700-04830

⑦ (For CE)

(FB10P-18P)

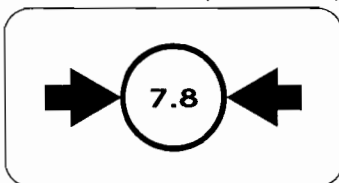

(FB20P-28P)

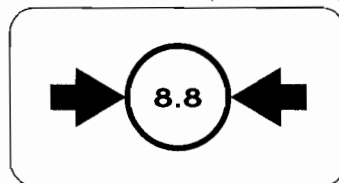

(FB30P)

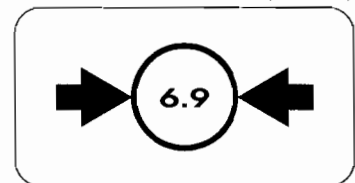

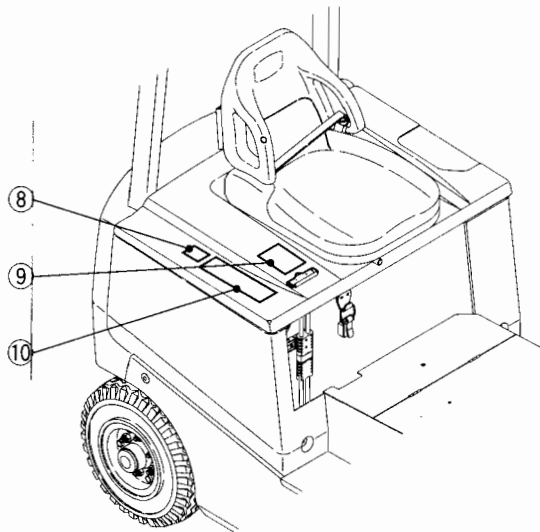

⑧ (Option)

⚠ DANGER

LASER LIGHT

- Do not stare into light.
- Do not light at people or animals.
- Do not use in area where any abnormalities may be occurred by laser light.
- Consult to physician immediately if any health problems are occurred by laser light.

24700-11570

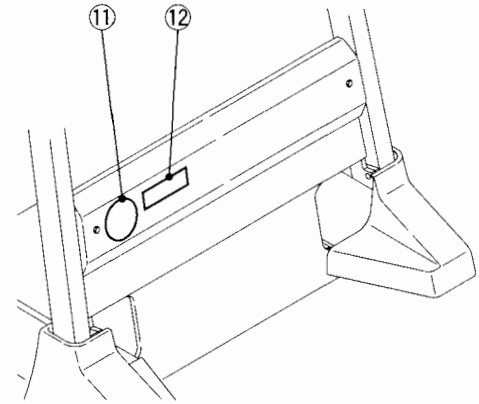

⑨

⚠ PRECAUTIONS FOR SAFETY OPERATION

- 1 Do not overload. observe allowable load (blue zone).
- 2 Prior to operation, check performance of brake or turn quickly.
- 3 Do not make a sudden start and brake or turn quickly.
- 4 Do not make a sudden valve lever operation at a high lift.
- 5 Do not run sideways or handle on an incline.
- 6 When the red lamp of battery capacity indicator turns on, charge battery.
- 7 Check electrolyte every week and replenish water.
- 8 Be sure to use the prescribed fuses.

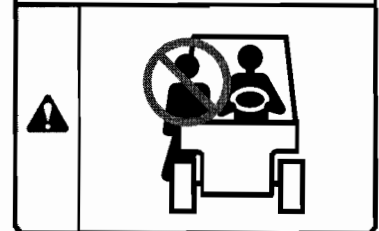

⑪

⑩

(For Std.)

MODEL NICHYU Nippon Yusoki Co., Ltd.

LOAD CHART

MAXIMUM LOAD/CLC	kg / mm	CAPACITY kg	LOAD CENTER mm	LIFT HEIGHT mm
LIFT HEIGHT	kg / mm			
SERIAL NO.	MFG. YEAR			
SHIP'G WEIGHT W/BATTERY	kg	VOLTAGE	V	
BATTERY WEIGHT	MIN kg	MAX kg	50006-91510 (英)	

(For CE)

MODEL CE NICHYU Nippon Yusoki Co., Ltd.

LOAD CHART

MAXIMUM LOAD/CLC	kg / mm	CAPACITY kg	LOAD CENTER mm	LIFT HEIGHT mm
LIFT HEIGHT	kg / mm			
SERIAL NO.	MFG. YEAR			
SHIP'G WEIGHT W/BATTERY	kg	VOLTAGE	V	
BATTERY WEIGHT	MIN kg	MAX kg	50006-91510 (英)	

JAPAN INDUSTRIAL VEHICLES ASSOCIATION

JVA

CERTIFICATE

This is to certify that this is a new fork lift truck which has been manufactured for exportation by **NIPPON YUSOKI CO., LTD.** as stated in the certificate issued by them.

⑫

(Option)

⚠ CAUTION レーザ光 LASER RADIATION

ビームをのぞき込まないこと
Do Not Stare Into Beam

Max Output < 1.0mW, Wavelength 630-690nm, CW, Laser Diode

クラス2レーザー製品 Class 2 Laser Product, JIS C 6802:1997

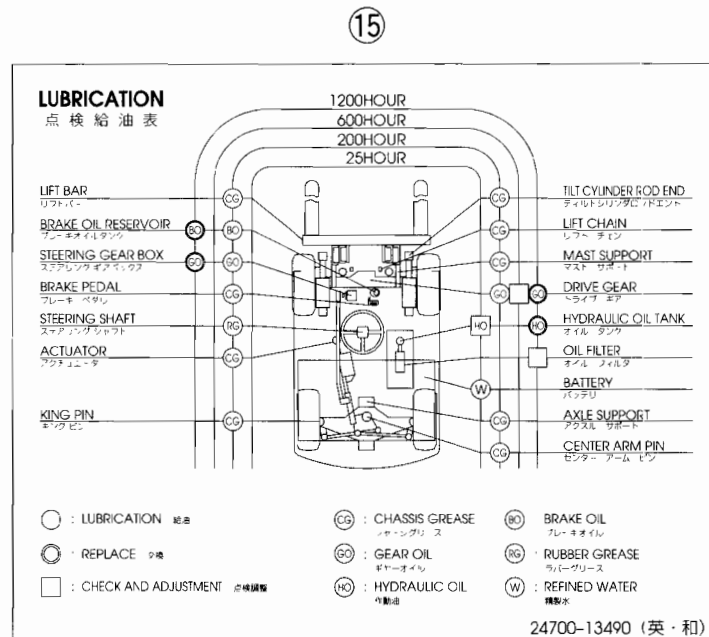
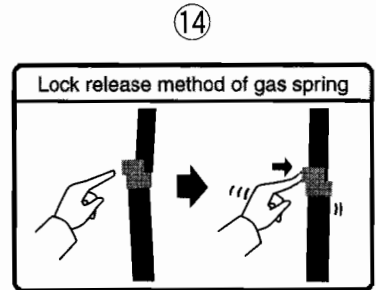
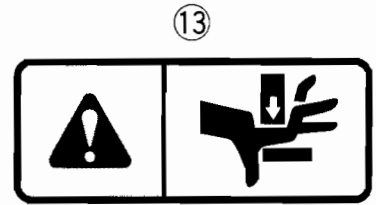
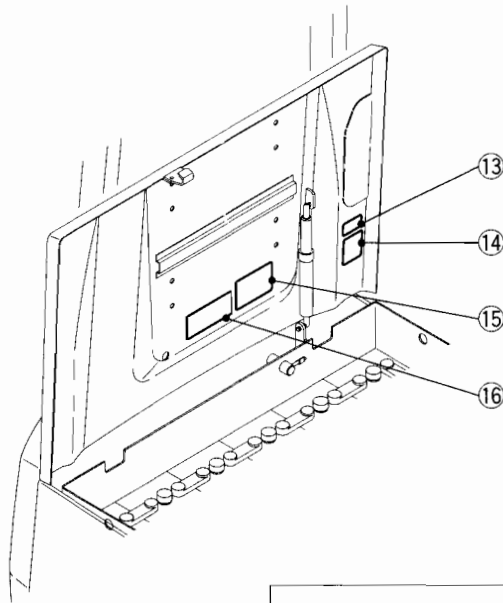

16

(with Japanese battery only)

⚠ DANGER

- GASES produced by this battery can be explosive. Cigarettes, flames, or sparks could cause battery to explode. Make sure batteries are stored and charged in a well-ventilated area.
- Batteries contain SULFURIC ACID can cause severe burns. Avoid contact with skin, eyes or clothing.
- In event of accident flush with water and call a physician immediately.
- Wear rubber gloves to prevent ELECTRIC SHOCK during checking and maintaining.
- Keep out of reach of children.

IMPORTANT POINT FOR MAINTENANCE

1. Maintain the proper electrolyte level. (When electrolyte is low fill with purified water to the white portion of the float, as shown in the figure.)
2. Always keep the batteries fully charged, do not overdischarge them.
3. Keep the battery surface clean.

Information for safety operation



Do not operate forklift truck while taking drugs and/or alcohol; otherwise, an accident may occur which can cause serious injury or death.



Only a trained and authorized operator shall operate the forklift truck.



The operator is recommended to wear a helmet, safety shoes and working clothes.



Do not use a forklift truck in the following circumstances.

- ① Where the temperature is less than -10°C (except cold-storage use forklift truck) or more than 40°C .
- ② Where the explosive gas (thinner, gasoline etc.) may exist.

When using a forklift truck in the following area, consult your local NICHYU dealer before operation.

- ① Where the explosive materials such as gunpowder are exist.
- ② The dusty place.



Keep the operator's compartment clean at all times.



Do not operate the forklift truck with greasy or wet hands.



NICHYU forklift trucks are equipped with an overhead guard and load backrest extension.

- These designed features are incorporated to protect the operator from falling loads.
- Make sure they are in place and in good condition.
- Precautions still should be exercised by the operator for possible falling objects or impacts.



Do not modify the forklift truck.

- Modifications and additions shall not be performed without the written approval of NICHYU. Contact NICHYU's qualified facility for details.
- Do not install any parts blocking visibility from operating position.





Carry out the daily inspection before operation.



- Stop operation and report immediately for any damage or faults on the forklift truck.
- Do not operate the forklift truck until it is repaired completely.



Do not overload. Failure to observe the rated capacity can cause the forklift truck to tip over.

- Refer to the load chart and make sure that the weight and the load center are within the capacity of your forklift truck before handling. If the attachment is installed on the forklift truck, the maximum capacity should be reduced. Read the instruction manual of the attachment before operation.



Use proper size pallet with enough strength for the load.

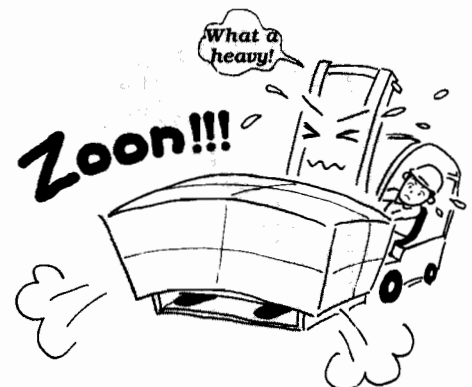



Make sure that the load is palletized securely in a proper shape. If a load is unstable, it can easily shift and fall on someone.



Fasten seat belt while operation.

- Adjust the seat position before turning on the key switch. After adjusting, jiggle the seat to make sure if it is properly locked.
- Adjust the seat and steering handle positions before operation for safety.



Do not adjust the seat while truck is in motion.

- **How to fasten the seat belt**
Grip the plate (connector) of the belt and pull it from the retractor. Then insert the tang into the slot of the buckle until a snap is heard. Make sure the belt is not twisted.

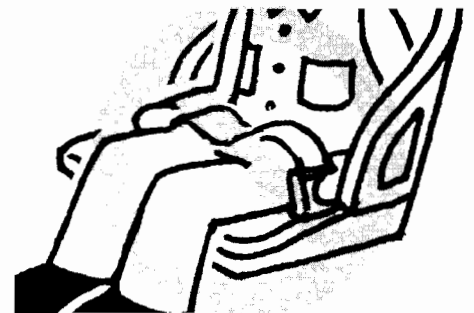
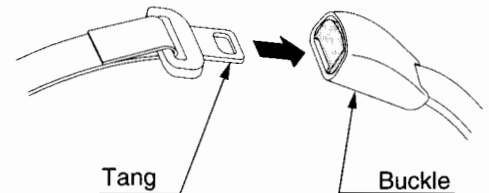

- **How to release the seat belt**
Push the button of the buckle to release the belt. The belt will automatically retract when release. Hold the plate of the belt and allow it to slowly retract.
- Be sure to fasten the belt across your hips, not across your abdomen.

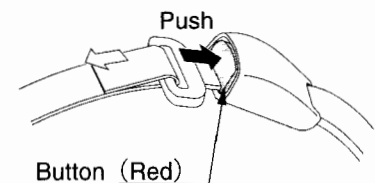

If you fasten the belt across your abdomen, the belt may tug your abdomen in the event of an accident.

- It is not necessary to adjust the belt length. The belt is designed to fit any size.



The seat belt would “jackknife” the operator. That is, the upper body would bend at the waist. If you are pregnant or have suffered from some abdomen disease, consult a physician before using the seat belt.



If the seat belt is torn, or damaged in an accident, replace it immediately.

- Contact your local Nichiyu service dealer for replacement.



Use neutral detergent or water to clean the belt. Do not use any solvent such as gasoline.



Look all around the forklift truck before moving.

- Make sure no person is around the forklift truck before starting.



Travel in backward if forward visibility is blocked.

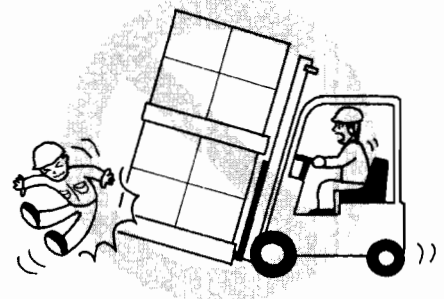

Make sure no person is around the forklift truck when traveling backward. Look around behind the forklift truck and sound the horn before moving.

- If the load blocks your view, or when you travel down a grade with a load, drive backward. Always look in the direction of travel. A look-out helper may be required if your visibility is obstructed.





Stop at blind corner and/or intersection.

- If you cannot see where you are going, don't move! Travel slowly around corners.
- Sound the horn at cross aisles and other areas where you cannot see clearly or where visibility is restricted.

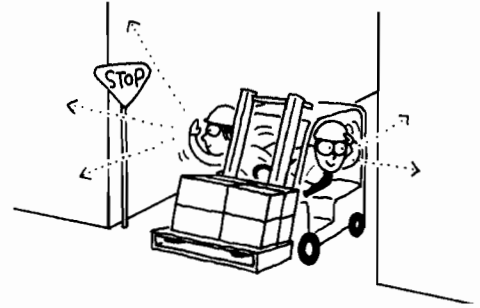

Always look in the direction of travel!

- Always be aware of people near your forklift truck. Do not proceed near them until they are aware of you.

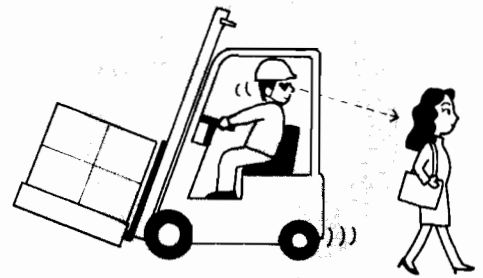

Be aware of tail swing.

- Always make sure that the tail swing area is clear before turning.
- When turning in aisles, especially narrow aisles, keep as far away as possible from stock and racks. Be extra cautious near people.
- Failure to observe the tail swing area when making a turn can injure or kill someone.

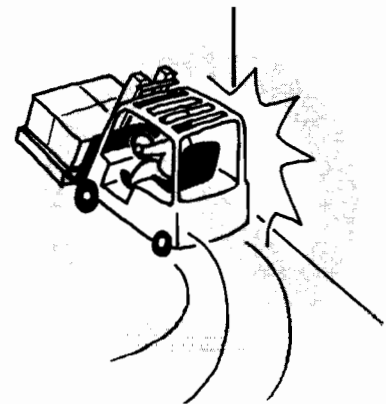

Do not make a sudden start, stop or turn.

- A sudden start or braking can cause the load to fall.
- A sharp turn while traveling can cause the forklift truck to tip over.





Do not go over obstacles, curbs, ditches, ridges and railroad tracks.

- Avoid bumps, holes, spill spots and loose materials that may cause the forklift truck to swerve or tip. If unavoidable, slow down, and proceed with caution.



Always check road surface, and stay away from soft or uneven ground to avoid a tip over.



Avoid slippery surface.

- Water, sand, gravel, ice or mud can cause a tipover. If unavoidable, slow down.
- Do not go into a flooded or water covered area.

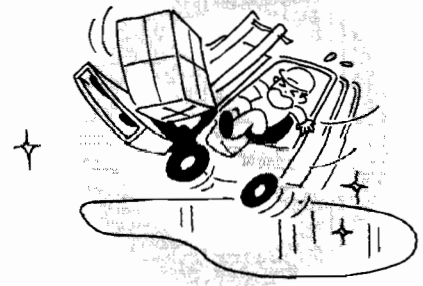

Keep enough clearance.

- Serious accidents can be caused by hitting pipes and beams near the ceiling with mast or overhead guard. Make sure there is enough clearance for ceiling and height limit of the entrance.

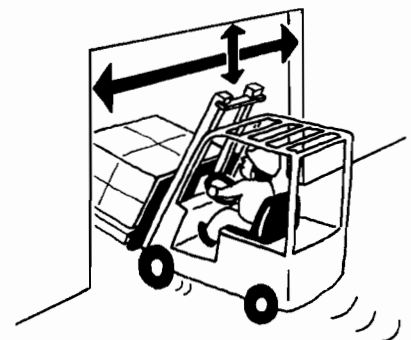

Do not exceed the limitation of the floor strength.

- A forklift truck is very heavy. Check the condition of the driving surface. Make sure the floor, bridge and/or elevator will support the weight of the forklift truck and the load.



Do not travel while the forks are in the raised position.

- Traveling while lifting the forks can cause the unstable condition to tip the forklift truck over.
- The fork height should be 150 to 200 mm high from the ground and the mast should be tilted back while traveling.

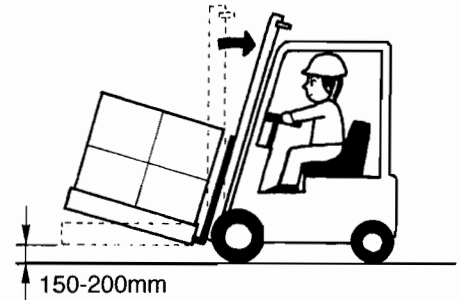
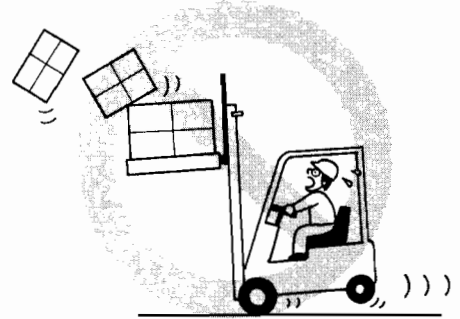

Do not push or drag the load.

- Do not lift the load by the tip of the forks.
- Misuse can damage the loads as well as the forklift truck.

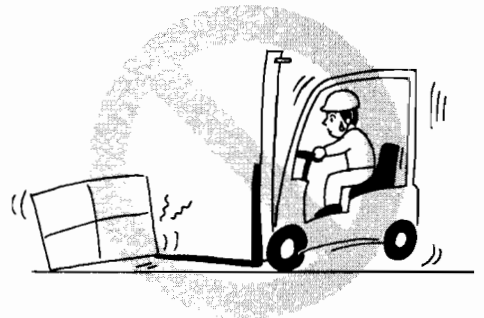
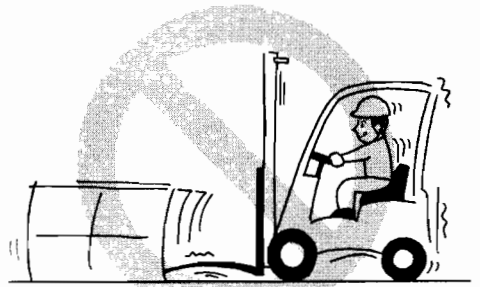

Never allow anyone to walk or stand under raised forks.

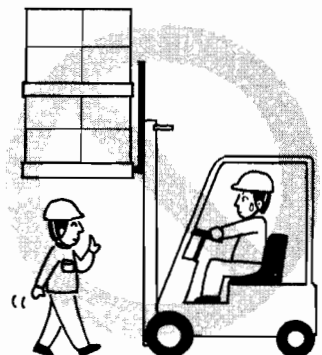



- Never allow anyone to ride on forklift truck other than operator.
- At no time shall anyone be allowed to ride on forks of forklift truck.



Keep enough distance from the edge of docks, ramps and platforms.



Travel carefully on grades with a loaded forklift truck.

- When traveling up or down a grade with a heavily loaded forklift truck, keep the load up grade to maintain control.
- Travel down with foot or plugging brake if necessary.

Loaded

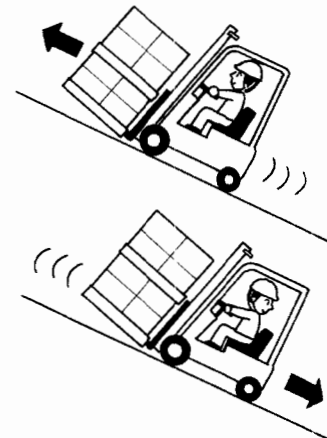

**Do not turn on, or angle across an incline.**

- Failure to observe this rule can cause the forklift truck to tip over.

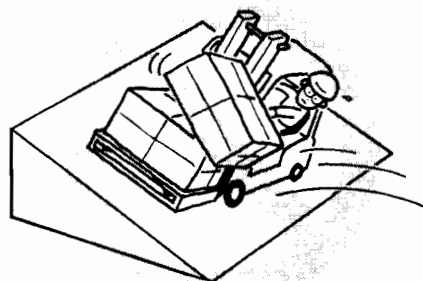
**Do not handle an off-center load.**

- If the weight of the load is not centered between the forks, the load can fall from the forks when you turn a corner or hit a bump.
- An off centered load will increase the possibility of the forklift truck tipping over to the side.

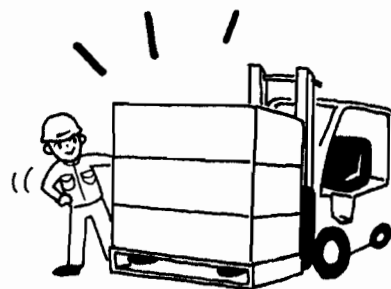
**Never put any part of your body into mast structure or between mast and forklift truck. Do not climb on the mast or overhead guard.****Do not put any part of your body outside operator's compartment of forklift truck.**

- Keep hands and feet inside the operator's compartment.





Operate hydraulic control levers slowly when loading or unloading.



Do not lower and stop the load suddenly.

- Failure to observe this instruction, can cause the forklift truck to tip over.

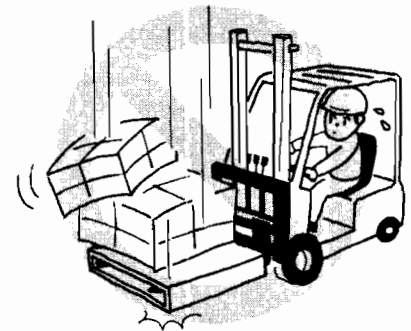

Do not tilt an elevated load forward.

- Tilt the mast backward enough and stabilize the load when traveling.
- Tilt the mast vertically when lifting.

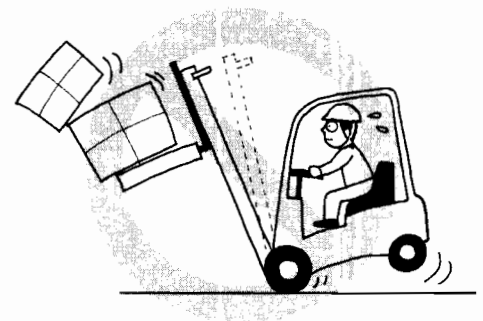

Drive into a trailer carefully.

- Make sure the trailer brakes are set and the wheels are blocked while loading or unloading.

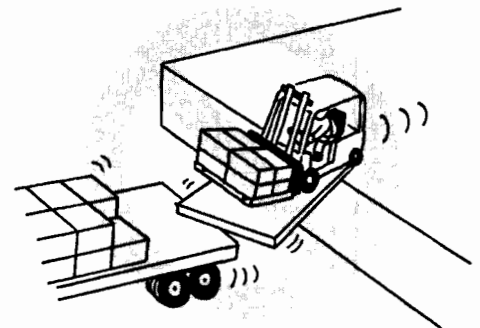



Do not jump on or off the forklift truck.

- Do not grasp the steering wheel or hydraulic levers to ride forklift truck.



Do not pick the loads up beyond the backrest extension height.

- When handling double stack loads, fasten together with a band to prevent the load from falling.

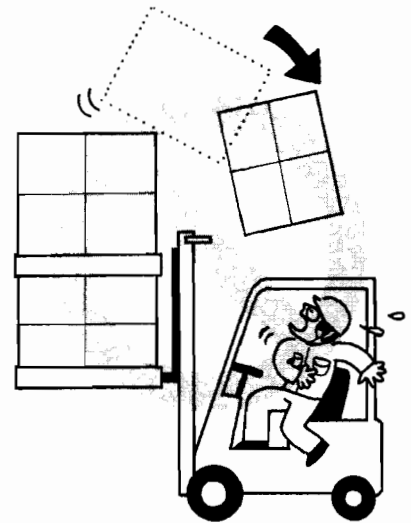

Do not pull the forks out from a pallet if chains are loosen.

- It is dangerous to have chains that are loose. It can cause the load to catch, racking by the forks or falling loads.



When chains are loosen :

- Lift the forks a little until correcting chains.
- After correcting chains, pull the forks out from a pallet.

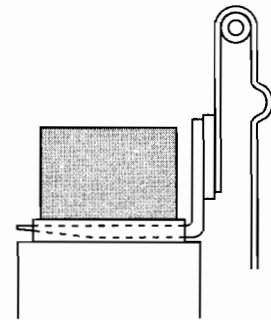

Do not abuse forks.

- Misuse can cause an accident as well as property damage.

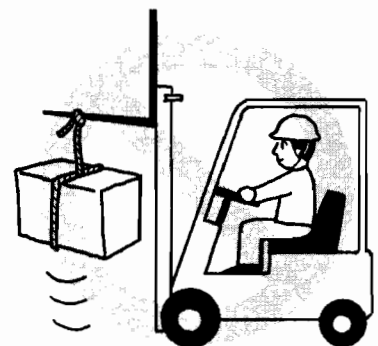



Do not tow anything by draw-bar pin.

- The draw-bar pin is equipped for towing the truck by another tractor if any problems occur.

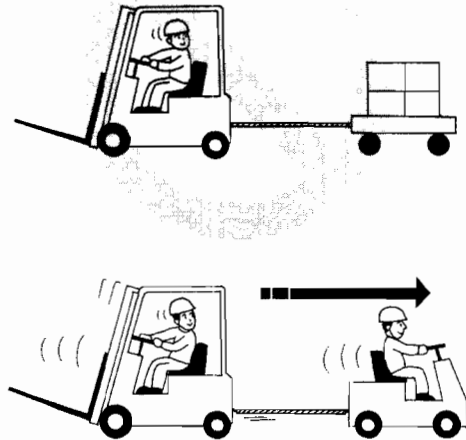

Avoid off-center loading.

- Set the forks as far apart as possible for the maximum support of the pallet or load.
- Improper spreading of forks can cause unstable or off-center loading.

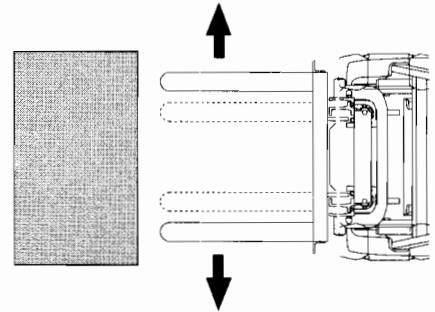

Make sure the fork set pins are applied correctly.

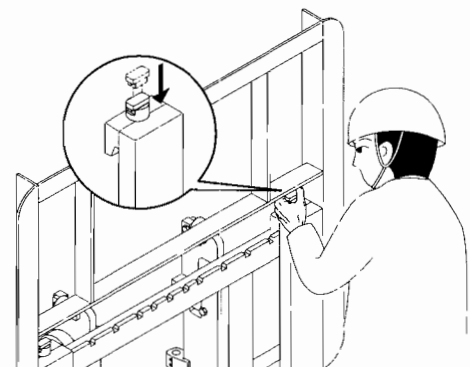

Travel carefully when handling a long or wide load.

- Be careful when handling a load. The load should be handled at a low lifting position.
- Lifting and lowering should be done slowly.

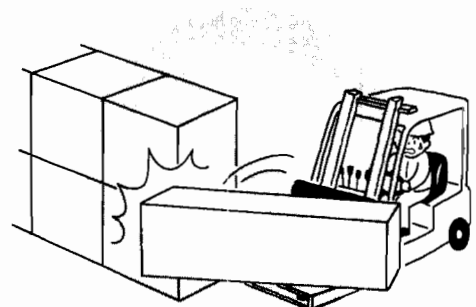

When carrying a wide load, the suitable wide bar should be mounted. (Option)



Never allow anyone to hold or pick loads off while traveling or lifting.

- Failure to observe this rule can cause serious personal injury.

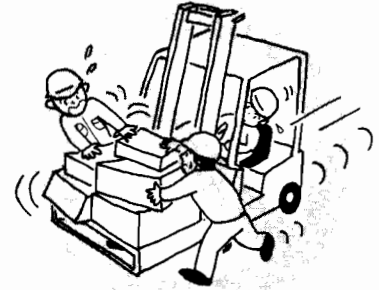

Do not use damaged pallets.

- Make sure pallets and skids are sturdy and in safe operating condition.



When parking the forklift truck:

- Tilt the forks down and lower on the ground.
- Apply the parking brake.
- Turn off the key switch and remove the key before leaving the forklift truck.

Parking place :

- Park the forklift truck at the reserved place.
- Do not park on or near flammable objects.

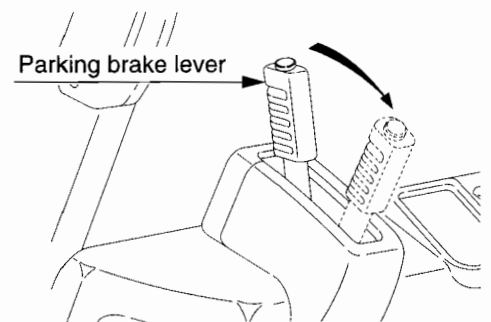

Do not park the forklift truck on a slope.

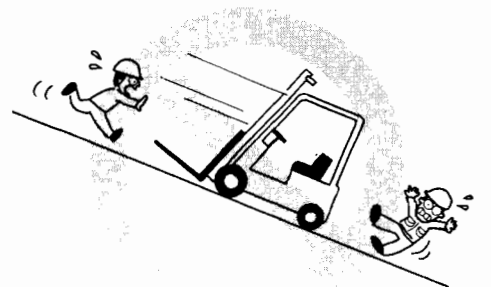

OUT OF ORDER LIFT TRUCK

- When parking a forklift truck requiring repair, a warning or "out-of-order" sign shall be placed on the forklift truck and the key removed.
- When the forks cannot be lowered because of a fault, place a large sign or marker on the forks. This procedure will caution other forklift trucks and pedestrians.

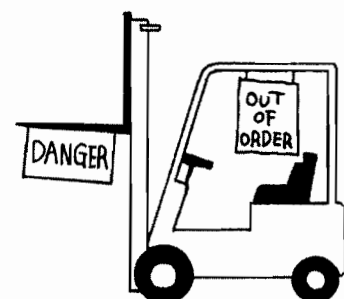

How to survive in a tip over

Safety notice for tip over

- Lateral tipover can occur when unloaded if the combination of speed and sharpness of turn produces an overturning moment which exceeds the stability of the forklift truck.
- Lateral tipover can occur if overloaded or loaded within capacity and the load is elevated and if turning and /or braking when traveling backward or if turning and/or accelerating when traveling forward produces an overturning moment which exceeds the stability of the forklift truck.

Backward tilt and/or off-center positioning of the load and/or uneven ground conditions will further aggravate the above conditions.

- Longitudinal tipover can occur if overloaded or when loaded within capacity and the load is elevated if forward tilt, braking in forward travel, or commencing backward travel produces an overturning moment which exceeds the stability of the forklift truck.
- Serious injury or death can occur to the operator if he/she is trapped between the forklift truck and ground.

In case of tip over

- The operator should stay with the forklift truck if lateral or longitudinal tipover occurs. The operator should hold on firmly to the steering wheel, brace feet, lean forward and lean away from the point of impact.
- The operator should stay with the forklift truck if it falls off a loading dock or ramp. There are other situations where the environment of the landing area presents a severe hazard. In those incidents, it may be prudent for the operator to leave the forklift truck.



In case of tip over:

- **Do not jump off.**
- **Hold on tight to steering wheel.**
- **Brace your feet.**
- **Lean away from impact.**

- Fasten seat belt while operation.

To survive in a tip over:

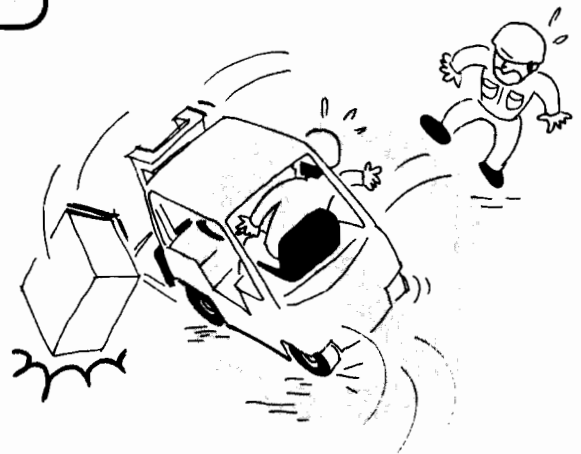

■ Name of part

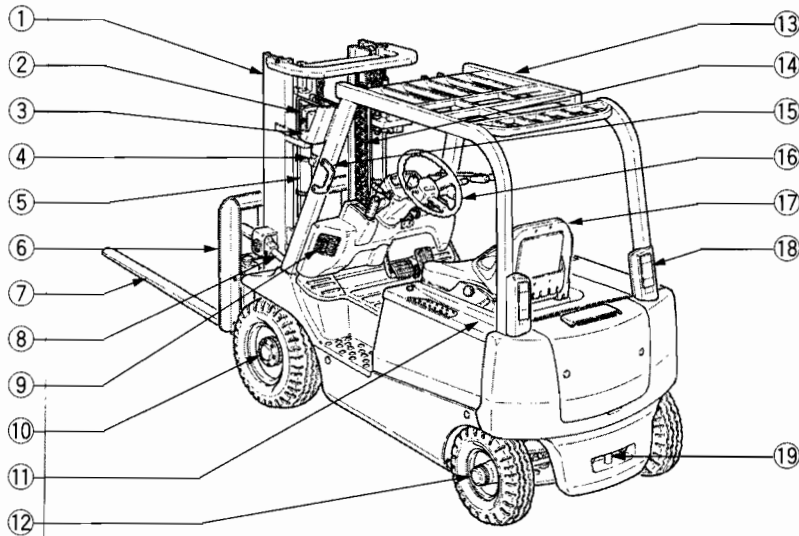

Illustration shows FB15P.

- ① Mast
- ② Head lamp
- ③ Turn signal lamp
- ④ Indicator lamp for fork leveling (Option)
- ⑤ Lift cylinder
- ⑥ Load backrest
- ⑦ Forks
- ⑧ Tilt cylinder
- ⑨ Built-in charger (Option)
- ⑩ Drive axle
- ⑪ Battery cover
- ⑫ Rear axle
- ⑬ Overhead guard
- ⑭ Lift chain
- ⑮ Assist grip
- ⑯ Steering wheel
- ⑰ Seat (w/Seat belt)
- ⑱ Rear combination lamp
- ⑲ Draw-bar pin

■ Driving equipment

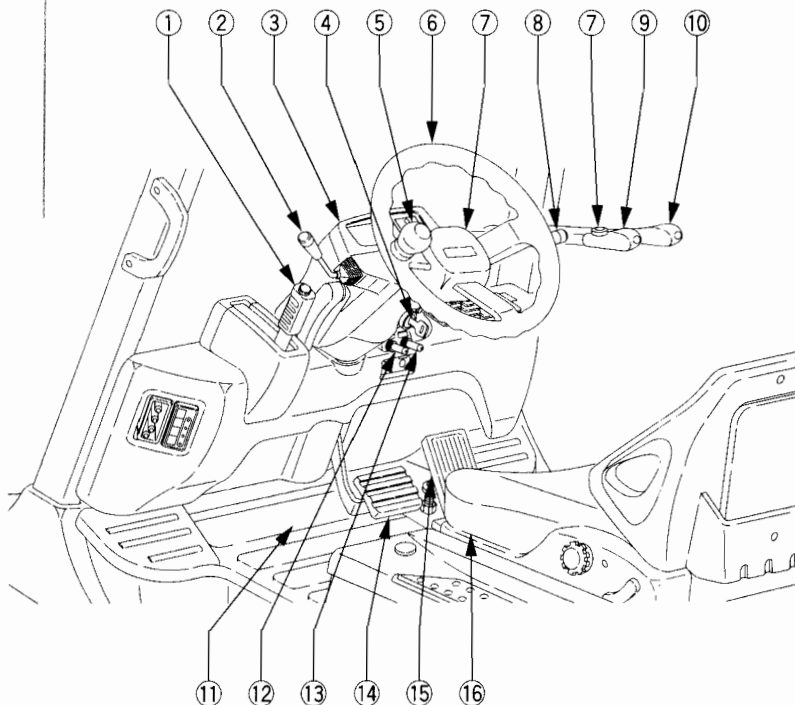
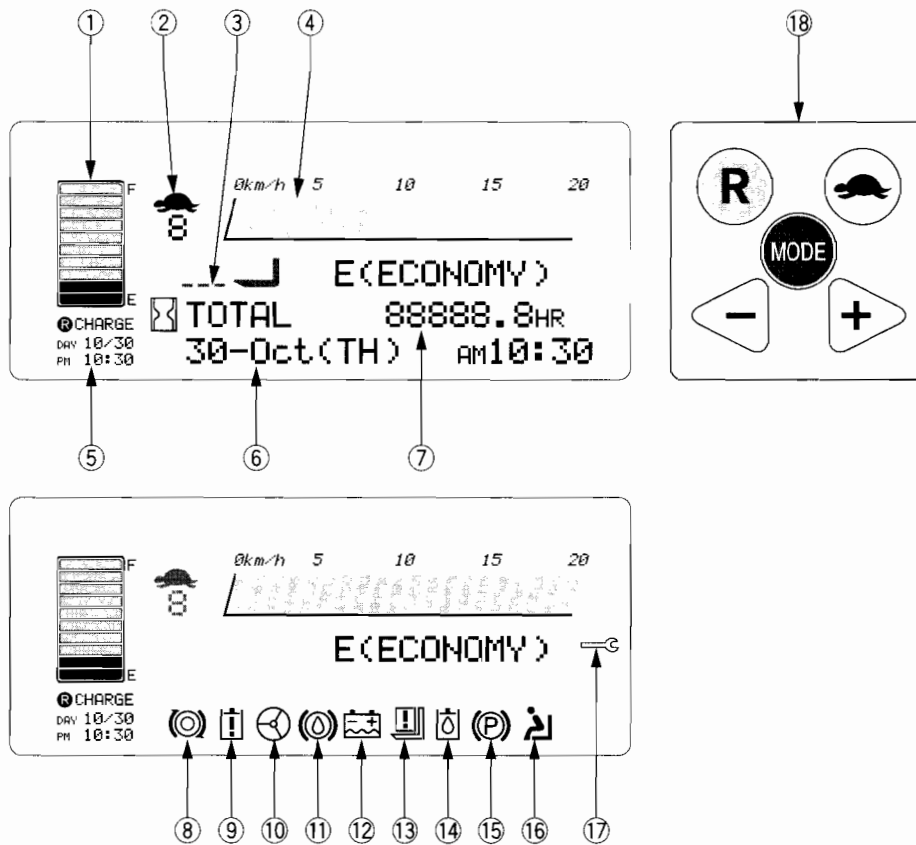

Illustration shows FB15P.

- ① Parking brake lever
- ② Turn signal lever
- ③ Indicator panel
- ④ Key switch
- ⑤ Steering wheel knob
- ⑥ Steering wheel
- ⑦ Horn button
- ⑧ Directional lever
- ⑨ Lift lever
- ⑩ Tilt lever
- ⑪ Floor plate
- ⑫ Lamp switch
- ⑬ Laser pointer switch (Option)
- ⑭ Brake pedal
- ⑮ Accelerator pedal
- ⑯ Seat (w/Seat belt)

Indicator panel



- ① Battery discharge indicator
- ② Slow speed mode monitor (Turtle mark)
- ③ Fork horizontal indicator (Option)
- ④ Travel speed meter
- ⑤ Battery charge reservation indicator (Option with built-in charger)
- ⑥ Calendar and clock
- ⑦ Hour meter
- ⑧ Safety monitor for traction circuit
- ⑨ Safety monitor for hydraulic circuit
- ⑩ Safety monitor for power steering circuit
- ⑪ Safety monitor for brake fluid
- ⑫ Safety monitor for battery electrolyte level (Option with GS battery)
- ⑬ Safety monitor for overload (Option)
- ⑭ Safety monitor for hydraulic oil level (Option)
- ⑮ Safety monitor for parking brake
- ⑯ Safety monitor for operator interlock system
- ⑰ Service (spanner) mark
- ⑱ Mode select button



Icons of ⑧ to ⑭, ⑯ and ⑰ shown in the illustration are displayed for the explanation. It is not actual indication. They are displayed when abnormalities are occurred.

■ Indication of display

When the key switch is turned on, the self-diagnosis function checks the control system and display "MONITORING OK" when no problems are found. Icons of "Read operator's manual" are flashed three times for warning to the operator.

After 2 or 3 seconds, the normal screen is displayed. If any abnormalities are detected, the error message is displayed. If the long message is displayed or some messages are displayed, they are scrolled from right to left alternatively.

When the key switch is turned on.

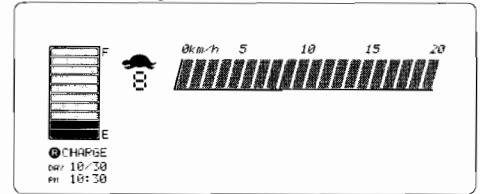

↓ After 0.5 seconds

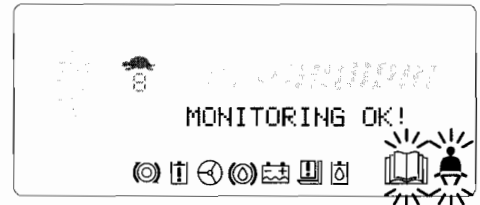

↓ After 2 or 3 seconds

Normal screen

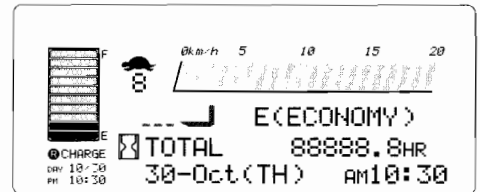

If traveling or hydraulic operation is done while this (within 3 or 4 seconds), the normal screen is displayed after finishing the initial monitoring function.



Contact to your local Nichiyu dealer if the error message is displayed.

▶ Mode select button

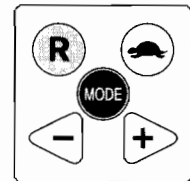

Mode selection

Push **R** button.



Reserve charge screen
 • Set the starting time of battery charge.

••• Refer the page 63 and the section of the reserve charging.

(This screen is displayed if the optional built-in charger is equipped.)

Push **MODE** button.
 (Release within 3 seconds.)



Mode select screen
 • Slow speed mode setting
 • Travel mode setting
 • Hour meter / odometer selection
 • Display mode setting
 • Coast mode setting

••• Refer to each setting section.

Push **MODE** button for more than 3 seconds.



Date / time setting screen
 • For setting of date and time.

••• Refer the page 32 for details.

Push one of **←** or **→**.



Hour meter screen
 • Three hour meters of traction, hydraulic and the total hour are displayed.

••• Refer the page 24 for details.

Function of display

This forklift truck has the self-diagnosis function.

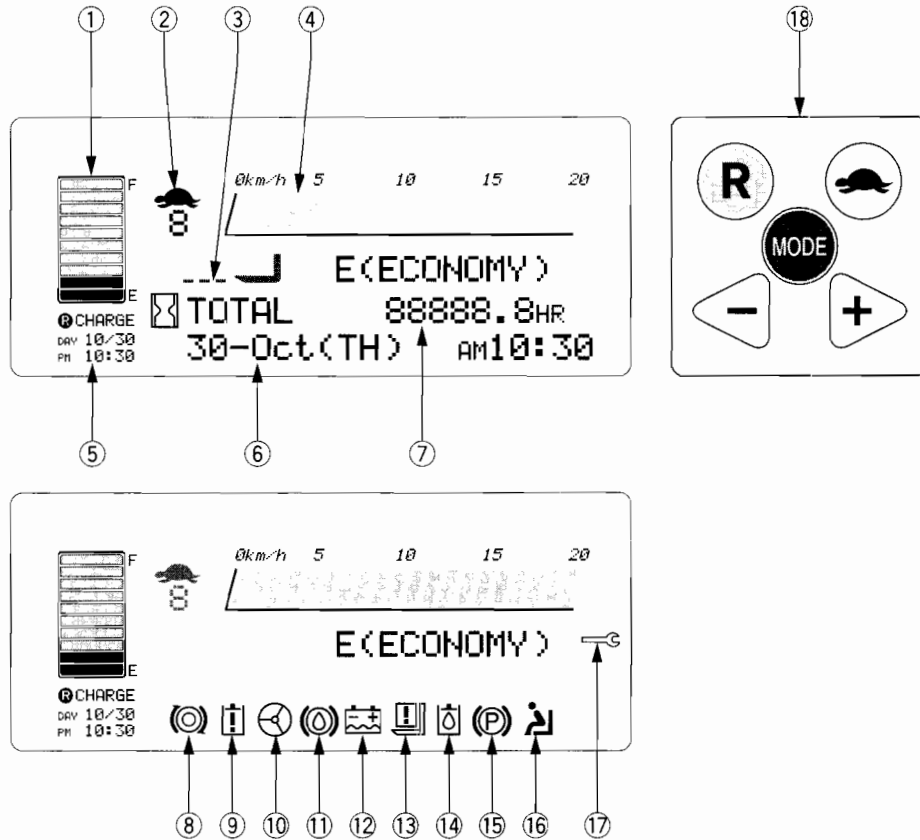

Icons of ⑧ to ⑭, ⑯ and ⑰ shown in the illustration are displayed for the explanation. It is not actual indication. They are displayed when abnormalities are occurred.

① Battery discharge indicator

The battery discharge indicator shows the discharged condition of the battery.



Do not over-discharge.

The battery life can be shortened by over-discharging.

Charge the battery immediately when all blue segments are disappeared on the battery indicator. (Then the lifting speed is reduced by half and warning message is appeared on the display)

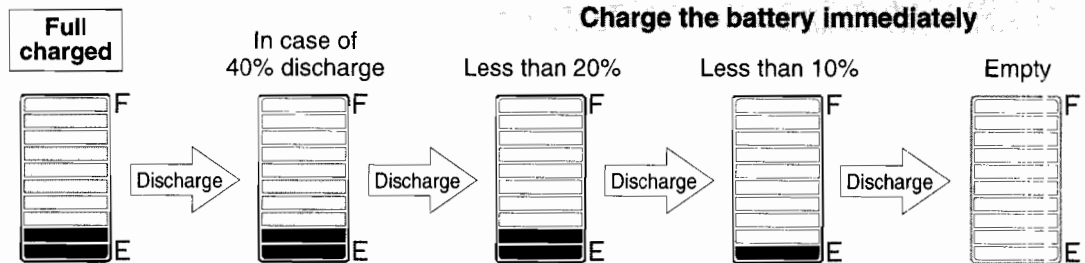

When the battery capacity is less than 20%, all blue segments are disappeared and two red segments are lit.

When the capacity is less than 10%, one red segment is flashed with the frame of the indicator. When the capacity is empty, only the frame of the indicator is flashed.

● **Lift interrupt (Option)**

When all green segments are disappeared and two red segments are lit, the lift speed is reduced by half. At the same time, “*CHARGE THE BATTERY*” message appears on the screen.

When the truck is continued to use, only one red segment is started to flash and the lift function is interrupted.

Two red segments are lit.

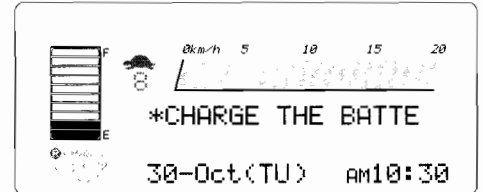

Lift speed is reduced to half.



One red segment is started to flash.

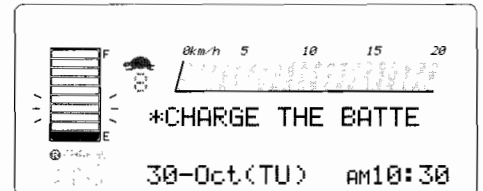

Lift function is interlocked.

② **Slow speed mode monitor (Turtle mark)**

When the turtle button is pushed, the turtle mark is indicated on the screen with the preset speed.

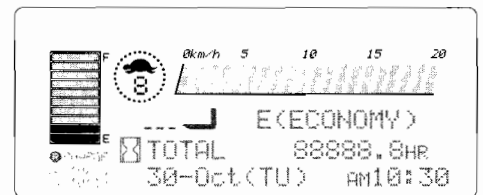

③ **Fork horizontal indicator (Option)**

This mark is indicated when the fork is horizontal and possible to use the laser pointer.

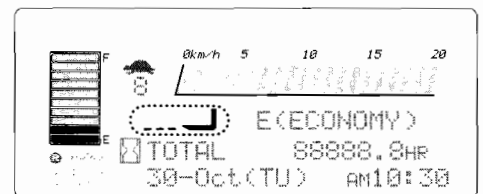

④ **Speedometer**

The traveling speed is displayed on the screen.

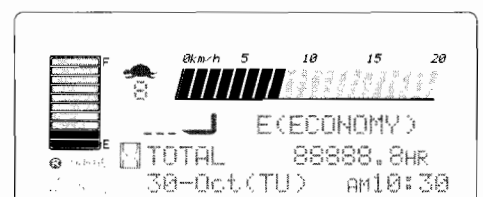

⑤ **Reserve charge indication (Option)**

The reserved date and time to start charging the battery is displayed. Refer the section of “Battery and charger” for details.

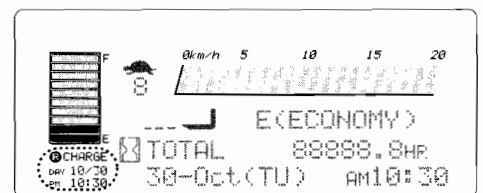

⑥ **Date and time (Calendar and clock)**

The current date and time are displayed. If the “MODE” button is pushed for more than 3 seconds, the display is changed to the setting screen. Refer the page 32 for details.

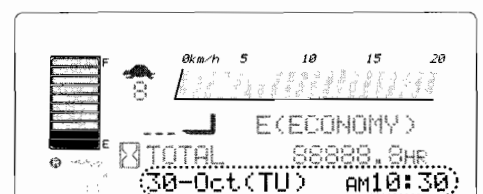

⑦ Hour meter

The hour meter shows the total hours of turning on the key switch.
 (The actual operating hours can be displayed as option.)
 It is useful to know the total operating hours for the daily job management and scheduling of the periodical inspection.

When pushing “◀” or “▶” button, each individual hours for travel, hydraulic and total are displayed for 5 seconds.

The normal screen and hour meter screen are changed by turn by pushing “◀” or “▶” button.
 After 5 seconds, the normal screen is displayed..

The odometer can be displayed in the normal screen instead of hour meter. Refer the meter mode setting in the setting mode section.



The hour meter screen is returned to the normal screen even less than 5 seconds by operating traveling or hydraulic function.

When the screen displays the odometer, the word of “TRAVEL” is flashed while travelling.

⑧ Safety monitor (for travel circuit)

When fault is detected in the travel circuit, the travel icon flashes and the presumed defective part name is displayed.

⑨ Safety monitor (for hydraulic circuit)

When fault is detected in the hydraulic circuit, the hydraulic icon flashes and the presumed defective part name is displayed.

⑩ Safety monitor (for steering circuit)

When fault is detected in the power steering circuit, the steering icon flashes and the presumed defective part name is displayed.

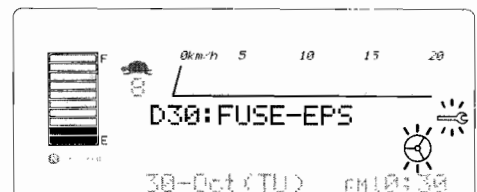
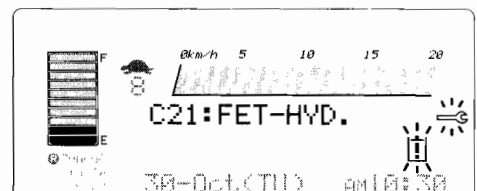
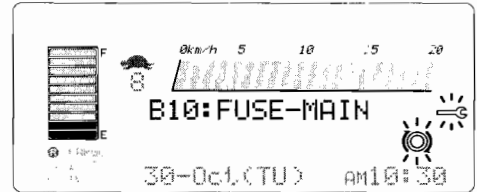
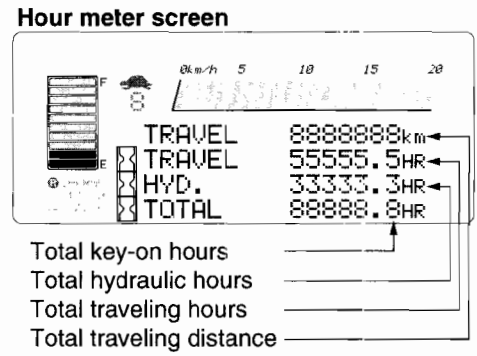
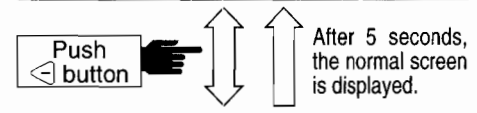
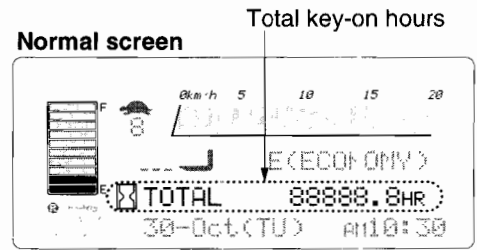

⑪ Safety monitor (for brake fluid level)

When the brake fluid level is low, the brake icon flashes and “*REFILL BRAKE OIL*” message is displayed.

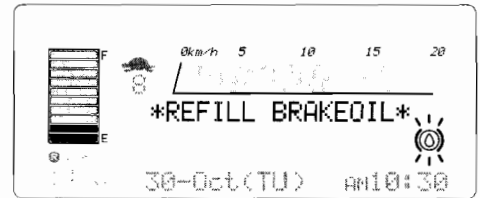

If the error message of parts or “*REFILL HYD. OIL*” is displayed*, contact to your local Nichiyu dealer to check the truck.

**⑫ Safety monitor (for battery electrolyte level) (for GS battery only)**

When the electrolyte level is lower than the specific level, the battery icon flashes and “*REPLENISH REFINED WATER FOR BATTERY*” message is displayed.

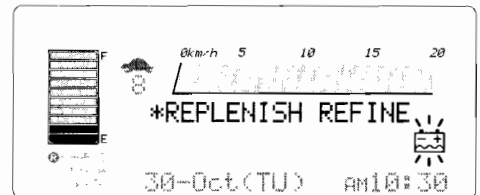
**⑬ Safety monitor (for overloading) (Option)**

When overloaded, the load icon flashes and “*REDUCE THE LOAD*” message is displayed on the screen.

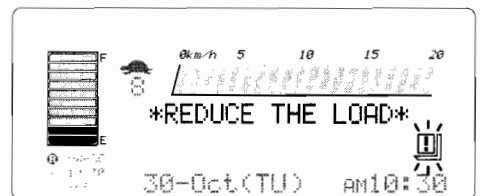
**⑭ Safety monitor (for hydraulic oil) (Option)**

If the hydraulic oil level is low, the icon is flashed and the message of “*REFILL HYDRAULIC OIL*” is displayed.

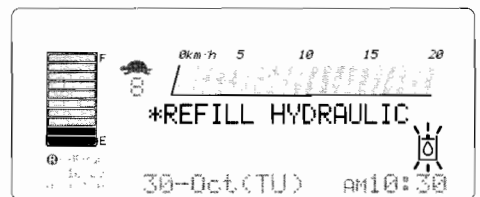

The hydraulic oil level sensor detects the oil level for 2 seconds after turning on the key switch. So, the mast must be retracted completely and fork must be lowered on the ground before turning on the key switch. Otherwise, the warning message of “*REFILL HYDRAULIC OIL*” may be displayed even the quantity of oil is normal.

**⑮ Safety monitor (for parking brake)**

When the parking brake lever is pulled, the parking brake icon is lit. If the operator moves the truck without releasing the parking lever, the icon flashes and the warning buzzer is beeped.



⑩ Safety monitor (Operation interlock system [OIS])

This system interlocks traction and hydraulic functions if the operator does not sit on the seat correctly.

If the operator leaves the seat when operating the truck, the OIS icon flashes to warn to the operator. If that situation is continued for more than 2 seconds, the buzzer beeps and all functions of traveling and hydraulics are interlocked. If the operator sits on the seat correctly within 2 seconds, the interlock does not activate and traveling and hydraulic functions are not interrupted.



- Even if the interlock is activated, the power for the motor is shut off but the brake is not applied. So, the truck keeps coasting. If the interlock is activated on a slope, the truck may be rolled back.
- When the interlock is activated, the hydraulic function will be started after 1 second if the operator sits on the seat with operating a hydraulic lever.

⑪ Service icon

The service icon warns the fault of the forklift truck to an operator. If any faults are detected, the spanner mark is flashed and the presumed defective part name is displayed. If some problems are occurred at the same time, each part name is scrolled alternatively for every 5 seconds.

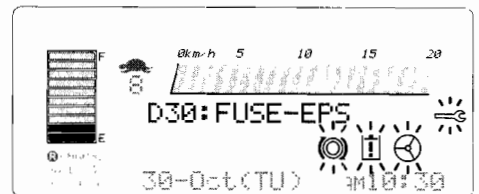

- If the next fault is detected, all travelling, hydraulics and power steering functions are shut down.
 - B11 : FET-TRAVEL
 - C21 : FET-HYD.
 - *FAIL CURRENT-TRAVEL*
 - *FAIL MAIN BOARD*
 - *FAIL CURRENT-HYD*
 - *FAIL OPERATION*
- All , , , buttons are invalid while displaying these messages.

18 Mode select button

Change the screen to each mode by pushing these buttons.

 Slow speed mode button

The slow speed mode is activated by pushing this button.

Normal traveling mode

When the slow speed mode is off, the turtle mark is not displayed.

Slow speed mode

When the slow speed mode is activated, the turtle mark and preset speed are displayed on the screen.

- The maximum travel speed (normal mode) and preset speed (turtle mode) can be changed by pushing the turtle button.

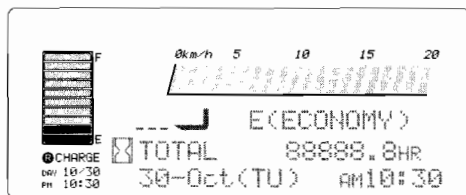
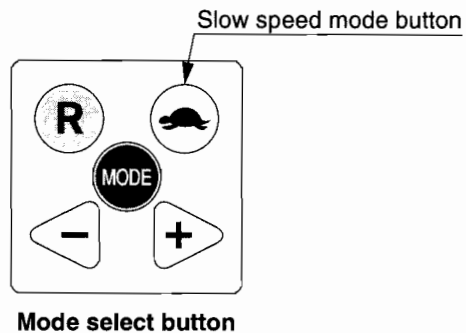

When the slow speed button is off
(Turtle mark is not displayed)

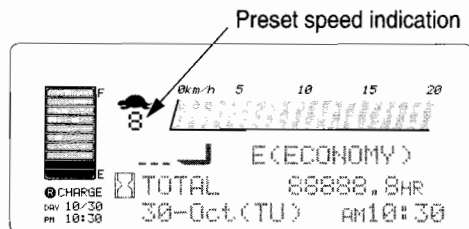

When the slow speed button is on
(Turtle mark is displayed)

Various kinds of mode selection

- 1 Slow speed setting
- 2 Travel mode setting
- 3 Meter mode setting
- 4 Display mode setting
- 5 Coast mode setting
- 6 How to set the date and time



- These settings are invalid while traveling or depressing the brake pedal.
- If traveling or hydraulic operation is done while setting, the display is returned to the normal screen immediately.

When pushing the "MODE" button, the mode selection screen is displayed. If pushing the "MODE" button again, the normal screen is displayed again.



When setting the mode of next 1 to 5, each button works as below.

- "<" and ">" buttons : Move the cursor to select the value.
- "R" button : Move the cursor to the next item.
- "MODE" button : Back the cursor to the previous item.

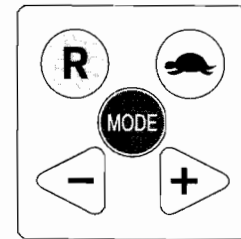

1 Slow speed setting

This mode sets the limited maximum travelling speed under the slow speed mode.

Make sure the turtle button is pushed and the turtle icon is flashed. Then, push "<" or ">" button to set the speed.

The maximum speed can be set to 8 steps of 2, 3, 4, 5, 6, 8, 10 and 12km/h.

After setting, push "R" button to move the cursor to the travel mode setting.

If push the "MODE" button, the normal screen is displayed.

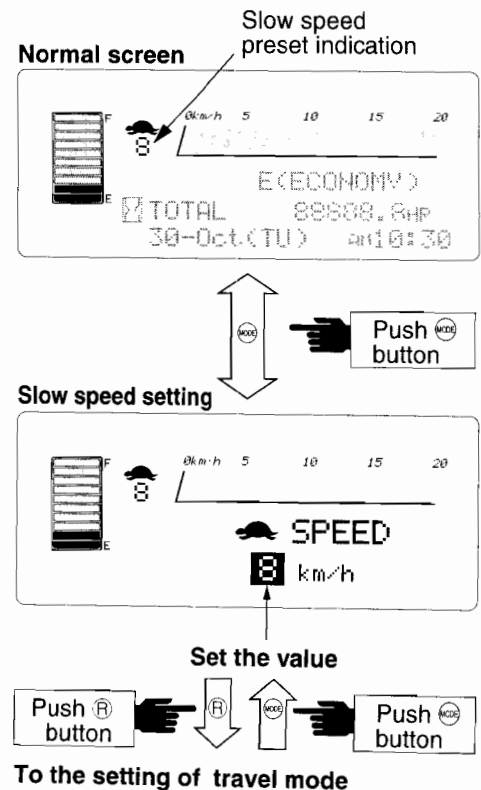

2 Travel mode setting

This screen is used to set the travel mode.

Make sure that the current traveling mode indication is flashed. Push “<” or “>” to select the mode.

After selection, push “R” button to move the cursor to the meter mode setting.

If pushing the “MODE” button, the cursor is moved to the slow speed mode setting.

The traveling mode can be set to the next three modes.

E (ECONOMY)

This mode is convenient for the slow speed inching. This mode saves the battery energy consumption also.

N (NORMAL)

This is the normal traveling mode. The quick acceleration and smooth inching can be realized.

P (POWER)

This is the most powerful mode for acceleration.

Travel mode setting

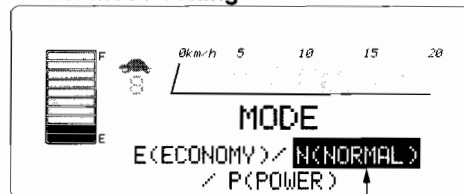

Set the travel mode.



To the setting of meter mode

3 Meter mode setting

The hour meter, odometer or load weight can be displayed on the normal screen.

When the cursor is located on the meter mode, press “<” or “>” button to select HR (hour meter), km (odometer) or kg (load weight : LARGE/NORMAL).

After selection, press “R” button go to the next step 4. To return to the previous step 2, press “MODE” button.

Meter mode setting

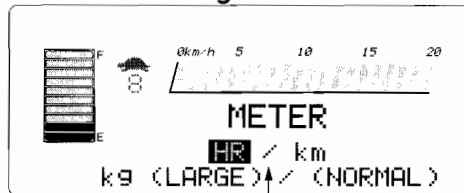

Select the meter mode.



To the display mode setting screen

kg (load weight : LARGE) screen [Option]

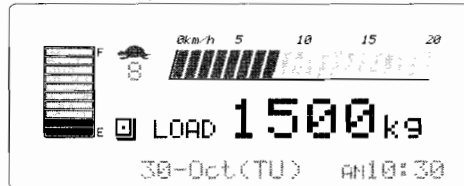

When setting “kg (LARGE)”, the travelling mode “E (ECONOMY)” • “N (NORMAL)” • “P (POWER)” is not shown on the display.

Every time when pressing “<” button on the normal screen, above meter mode setting screen and the normal screen are displayed alternatively. (Refer the next page for details)

Normal screen and meter mode screen

In the case of the hour meter (HR) mode

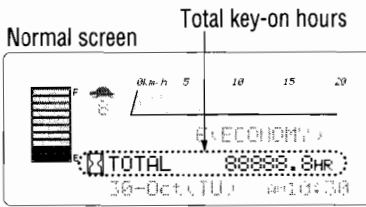

In the case of the odometer (km) mode

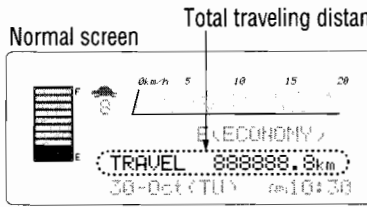

In the case of the load weight (kg) mode (Option)

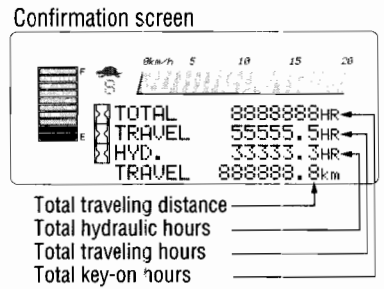
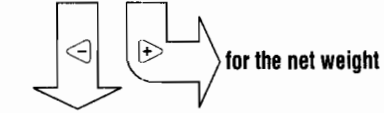
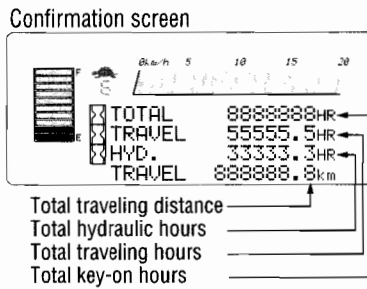
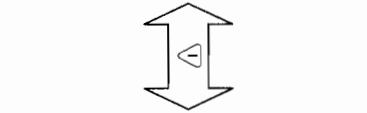
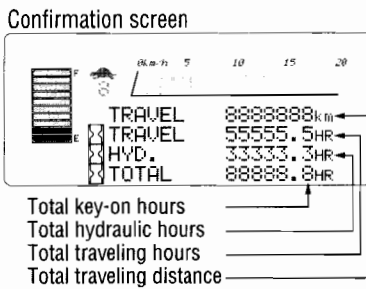
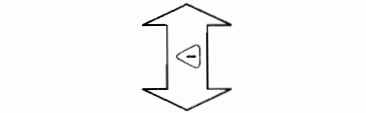
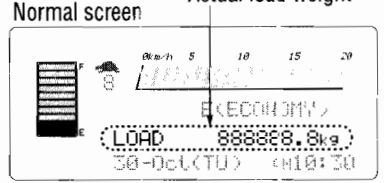

* The normal screen is displayed even within 5 seconds when the traveling or hydraulic operation is done.

○ Load weight indication (Option)



- The load weight indicator is equipped for safe operation, however, the indicated value should be used as reference.
- The weight must be measured after raising the fork about 500 mm high from the floor and stop hydraulic and travelling operation.
- This function cannot be used as the formal weight scale.

Load weight setting screen

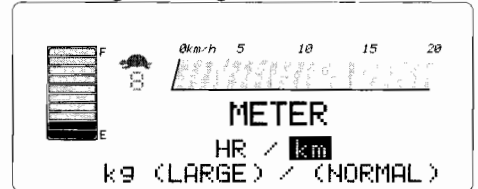

Select "kg" mode.

Raise the load about 50 cm high above the floor. After releasing the hydraulic lever, "LOAD" message flashes for 5 seconds because the hydraulic pressure is fluctuated while hydraulic operation. Read the weight after "LOAD" message is fixed.

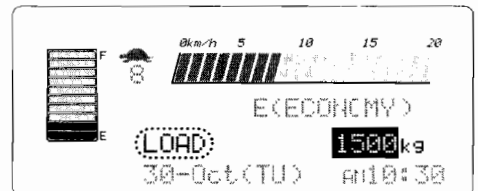

- If the loading weight is more than 110% of the loading capacity on the name plate, the "LOAD" message is changed to "OVER". This "OVER" message flashes and the warning buzzer is also beeped.
- The setting of overload can be changed. Consult to your local Nichiyu service dealer for details.

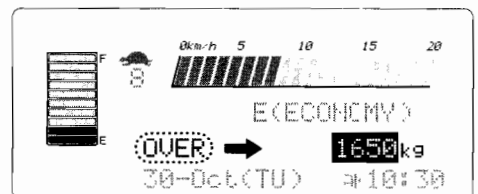



Zero adjustment (for net weight)

If you want to deduct the pallet weight to get the net weight of the load, press “+” button. Then the zero adjust icon is indicated and the indicated weight is changed to 0 (zero) kg.

By pressing the “+” button again, this function is turned off.

This function cannot be changed when “LOAD” message is flashed.

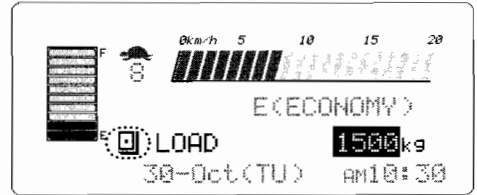

4 Display mode setting

This mode sets the brightness of the screen.

Make sure that the cursor is located on the brightness setting area. Push the “<” or “>” button to select the brightness for the best. It can be selected 8 steps (from 0 to 7).

After setting, push “R” button to get the coast mode setting screen.

If pushing the “MODE” button, the cursor is returned to the view (contrast) setting.

Display mode setting screen

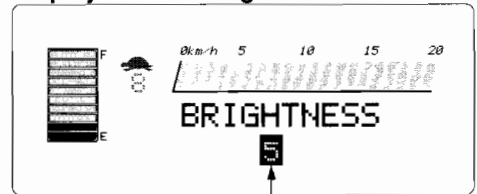

Set the brightness



To the setting mode of regeneration (coast mode)



Refer the table below for the brightness settings.

BRIGHTNESS (Intensity of back light)	
0 Dark	7 Bright

Setting mode of regeneration (coast mode)

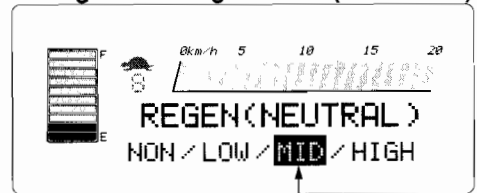

Set the regenerative braking force when coasting.



Return to the normal screen.

5 Coast mode setting

This mode can set the regenerative braking force when releasing the accelerator lever while travelling.

Make sure that the REGEN(NEUTRAL) mode screen is displayed. Then push “<” or “>” button to select the strength.

The braking strength can be set to 4 steps of “NON” (No braking), “LOW”, “MID” (Middle) and “HIGH”.

After setting, push “R” button to return to the normal screen.

If pushing the “MODE” button, the display mode setting screen is displayed.

6 How to set the date and time

When the "MODE" button is pushed for more than 3 seconds, the date and time setting screen is displayed. Push "MODE" button to return to the normal screen.



If traveling or hydraulic operation is done while setting, the display is returned to the normal screen immediately.



When setting the mode of next ① to ⑥, each button works as below.

- "<" and ">" buttons : Move the cursor to select the value.
- "R" button : Move the cursor to the next item.
- "MODE" button : Back the cursor to the previous item.

① Set the year

Make sure the cursor is located on the year area. Push "<" or ">" button to set the year. The year can be set from 2000 to 2999.

After setting, push the "R" button to move the cursor to the month area.

If push the "MODE" button, the normal screen is displayed.

② Set the month

Make sure the cursor is located on the month area. Push "<" or ">" button to set the month. the month can be selected from 1 to 12.

After setting, push "R" button for the date setting.

If pushing "MODE" button, the cursor is returned to the year area.

③ Set the date

Make sure the cursor is located on the date area. push "<" or ">" button to set the date. The date can be set from 1 to 31. When setting the date, the day of the week is set automatically.

After setting, push the "R" button to move the cursor to the AM/PM area.

If pushing "MODE" button, the cursor is returned to the month area.

Normal screen

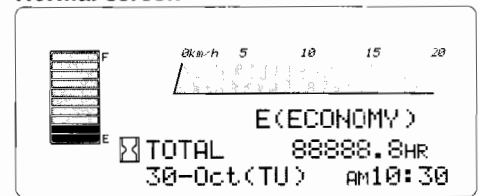

Push "MODE" button for more than 3 seconds.

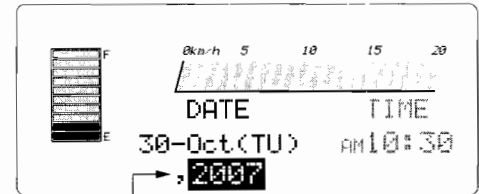

Year is flashed.

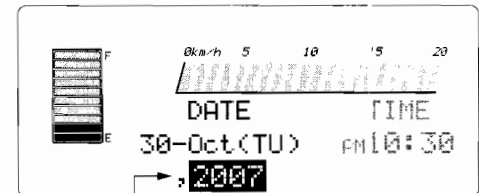

Set the current year.

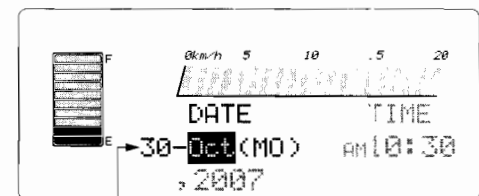

Set the month

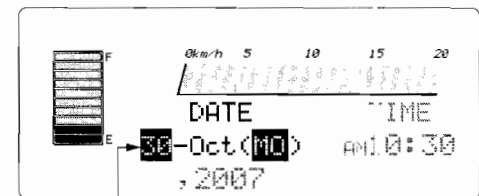

Set the date
(Day of the week is set automatically)

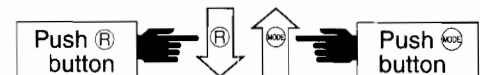

④ Set the AM or PM

Push the “<” or “>” button to select the AM or PM. After setting, push the “Ⓡ” button to move the cursor to the hour area.

If pushing “MODE” button, the cursor is returned to the data area.

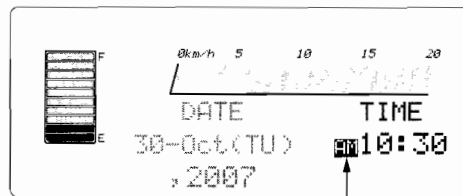

Set “AM” or “PM”.

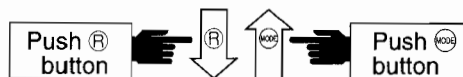

⑤ Set the hour

Push the “<” or “>” button to set the hour. The hour can be set from 1 to 12.

After setting, push the “Ⓡ” button to move the cursor to the minute area.

If pushing “MODE” button, the cursor is returned to the AM or PM area.

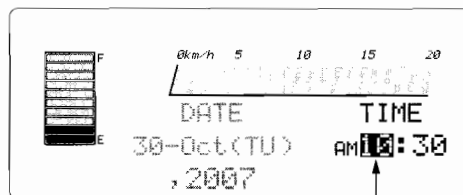

Set the hour

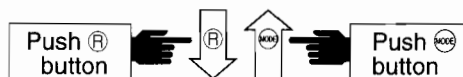

⑥ Set the minute

Push the “<” or “>” button to set the minute. The minute can be set from 00 to 59.

After setting, push the “Ⓡ” button.

Then “COMPLETE” message is flashed three times. In any cases, push “MODE” button to get the previous step.

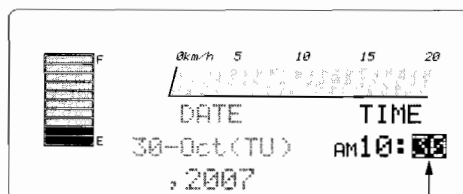

Set the minute

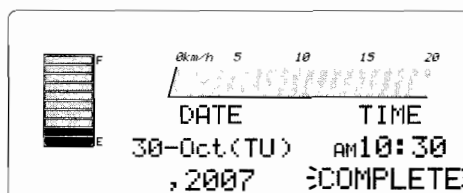

“COMPLETE” is flashed three times.



Return to the normal screen.



- When pushing the “<” or “>” button, the second is set to “00”.
- After setting the minute and push the “Ⓡ” button, the second is set to “00”.
- If set the date and time, the reserve charge setting is also renewed.

■ Operating equipment

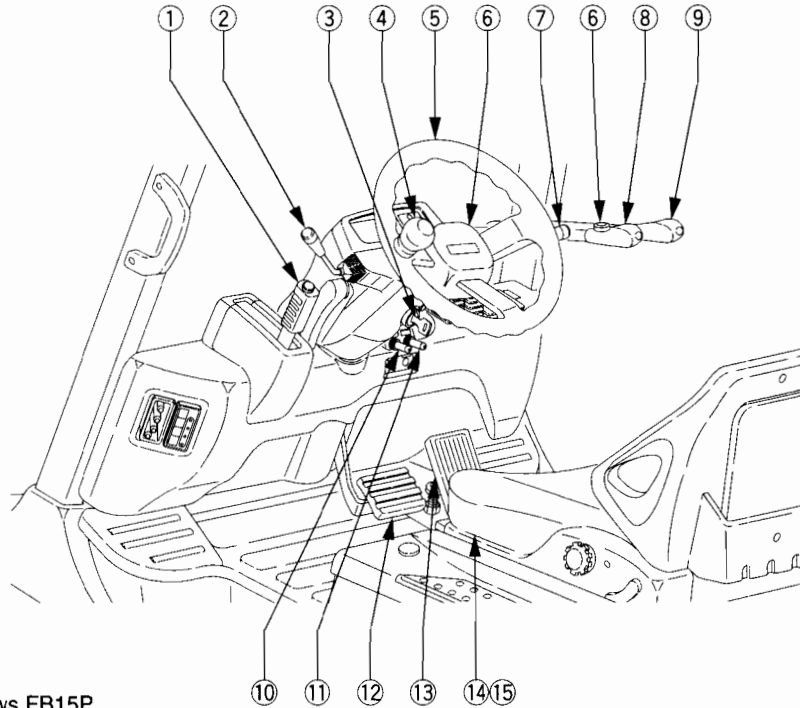
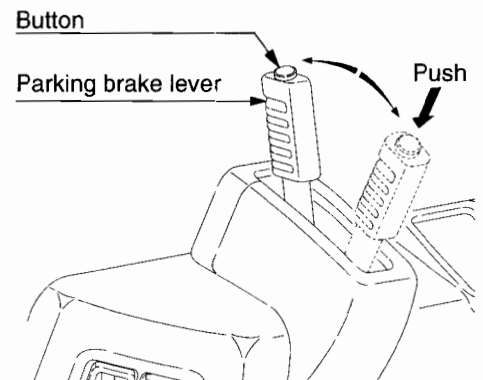

Illustration shows FB15P.

① Parking brake lever

When parking the lift truck, pull the lever fully to apply the parking brake. To release the brake, push the top button and push the lever forward.

When the parking brake lever is pulled, the parking brake icon is lit. If the operator moves the truck without releasing the parking lever, the icon flashes and the warning buzzer is beeped.



- When parking the lift truck, lower the forks on the floor and pull the parking brake lever completely.
- When leaving the lift truck, turn the key switch off and remove the key.
- When operating the parking brake lever, depress the brake pedal.



② Switch for turn signal lamp

Use turn signal lamp when turning.

Move up the lever :

The right signal light is flashed for the right turn.

Move down the lever :

The left signal light is flashed for the left turn.

- Turn signal light is cancelled when the switch is moved to the opposite direction.

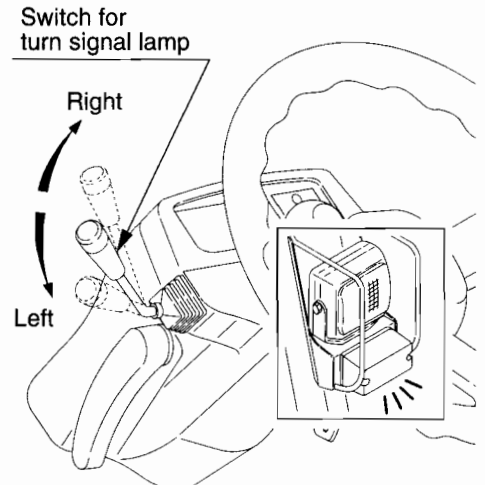

The turn signal lever is returned to neutral position when released. By turning the steering wheel to the opposite direction, or after 7 seconds, the signal light is turned off automatically.

**③ Key switch**

OFF : This position turns off all electric circuit except some accessories and the key can be put in or taken off.

ON : After turning on all electric circuit, the key switch is held in this [ON] position.

START : This [START] position connects all electric circuit to allow the operation of the forklift truck and monitor display is turned on.

The key is returned to [ON] position automatically by releasing.

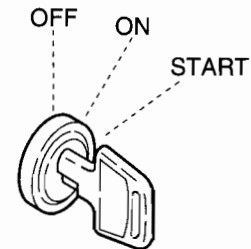

Automatic power off function :

Suspending the travel and hydraulic operation for 15 minutes, electric circuits are turned off automatically.

Turn the key switch into the [START] position to turn the power on again.

④ Steering wheel knob, ⑤ Steering wheel

Grasp the steering wheel knob by the left hand. The right hand should hold the hydraulic levers lightly or put on the steering wheel.

- The electric power steering (EPS) and tilt steering column is the standard equipment.



Adjust the steering wheel for your best operating position by the tilt steering lever.



After adjusting the steering tilt angle, tighten the tilt steering lever securely.

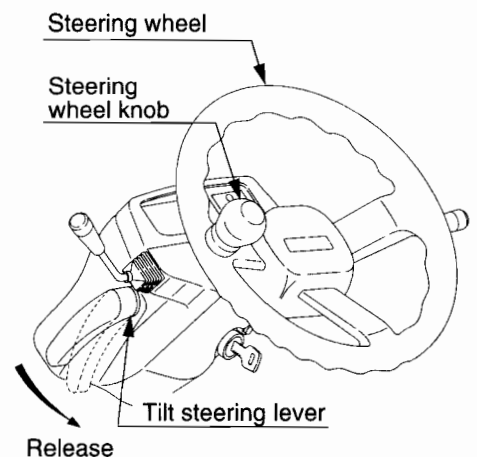

⑥ Horn button

Horn button is located on the center of the steering wheel and the tilt lever. Press the button to operate the horn.

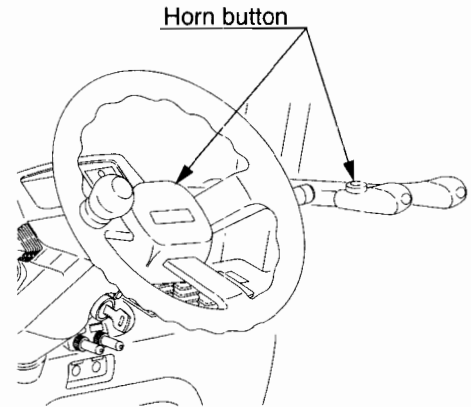

⑦ Directional lever

This lever is used to change the direction of traveling.
For forward : Move the lever forward and depress the accelerator pedal.

For backward : Move the lever backward and depress the accelerator pedal.

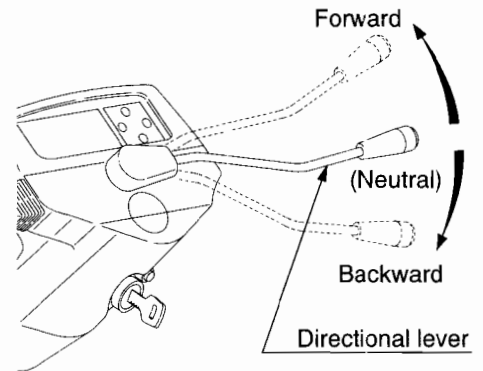

- Travel speed is changed by depressing angle of the accelerator pedal.
- When starting, turn on the key switch, move the directional lever to forward or backward, and depress the accelerator pedal gradually.



Do not flip the directional lever when changing the direction.

- It is dangerous because the directional lever is flipped back to unexpected direction.



- **Avoid fast start and sudden movements. This can cause the lift truck to tip over. Such movements can cause people to be hurt or killed and material can also be damaged.**
- **When parking the lift truck, place the directional lever to neutral position.**

⑧ Lift lever

Lifting up the forks : Pull the lift lever backward.

Lowering the forks : Push the lift lever forward.



Lifting and lowering speed can be controlled by stroke of the lift lever. Do not operate it roughly.
The lift function will not activate if the lift lever is operated before turning on the key switch.

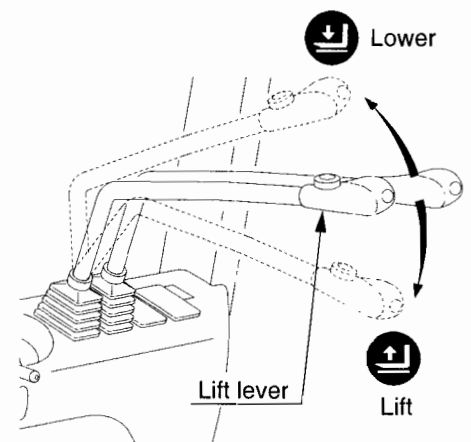

Do not stop lifting or lowering suddenly.

⑨ Tilt lever

Tilting backward : Pull the tilt lever backward.
 Tilting forward : Push the tilt lever forward.

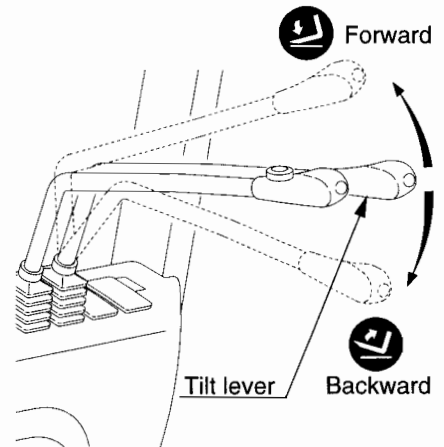

Tilt speed can be controlled by stroke of the tilt lever. Do not operate it roughly.
 The tilt function will not activate if the tilt lever is operated before turning on the key switch.

**⑩ Switch for head lamps**

Turn the lever up : Head and tail lights are turned on.
 Turn the lever down : All lights are turned off.

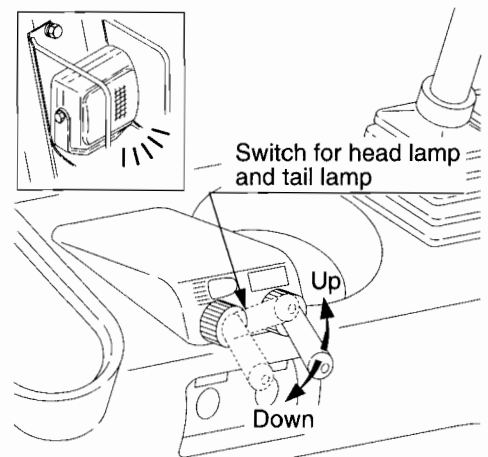
**⑪ Switch for the laser pointer (Option)
(Refer the page 39 for details.)**

To power on the laser pointer, turn the switch lever up.
 When the fork is leveled, the laser pointer irradiates the laser beam and the fork leveling indicator lamp is lit.

To power off, turn the lever down.

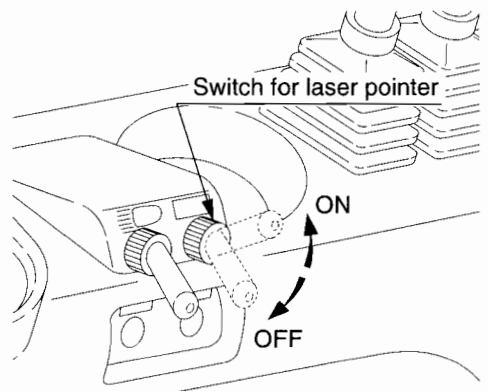
**⑫ Brake pedal, ⑬ accelerator pedal**

Depress the accelerator pedal gradually. Travel speed can be adjusted by depressing angle of the pedal.

Do not depress the accelerator pedal and brake pedal at the same time. The traction motor may be damaged if this occurs.

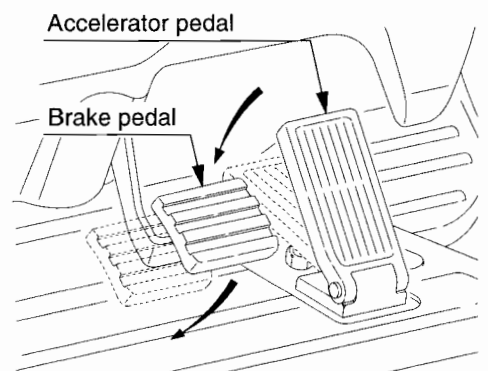

⑭ Seat

Operator restraint type seat is equipped as standard. It is adjustable for the best position to forward or backward.

Adjust the seat for proper operating position. The operator's manual can be stored in the box behind the back of the seat.

Adjustable position of the seat

Forward : 60mm

Backward : 60mm

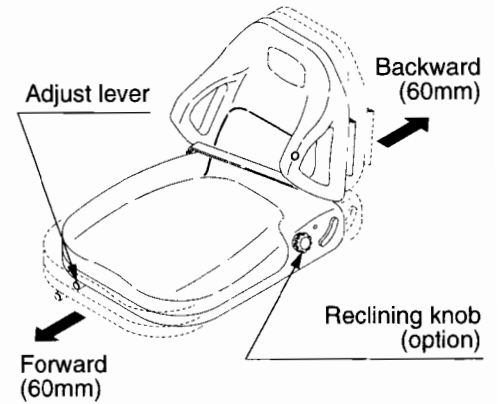

■ Laser pointer (Option)

▶ Function

The laser pointer is the laser-pointing device for a pallet to find the fork inserting position easily.

▶ Specification

Voltage of power supply :

3 volts D.C. (supplied from the power circuit of a forklift truck)

Length of beam (Line type) :

Approximately 500 mm long at 1 m ahead

Width of beam (Line type) : 1 through 3 mm wide

Diameter of beam (Point type) : 2 through 5 mm dia.

Lighting power : Less than 1 mw

Laser class : 2

▶ Features

● The laser beam

Line type (Standard)

The light beam is a line and easy to find out on a pallet.

- ⇒ It is suitable for a bright colored pallet or using in a dark warehouse.

Point type (Option)

The light beam is the dot. It is brighter than the line type but it may not be easy to find the dot.

- ⇒ It is suitable for the dark-colored pallet or using in a well-lighted warehouse.

● Fork leveling indicator lamp (set option with the laser pointer)

When the fork is leveled, the fork icon is appeared on the display with beeping the buzzer.

Another indicator lamp on the lift cylinder is also illuminated.

Operator can make sure the fork is leveled not only for picking the pallet but for pulling the fork out also from the pallet when stacking.

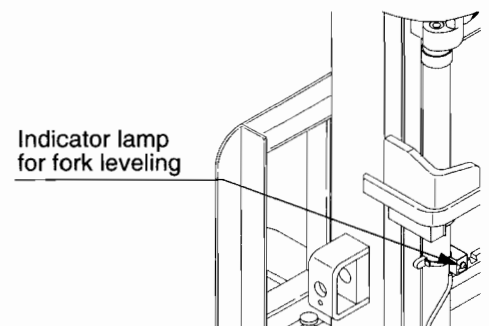
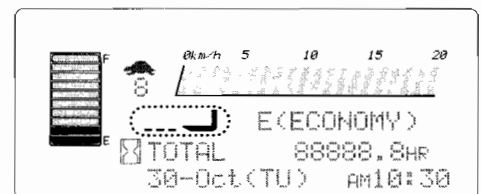

The fork level indicator lamp indicates that the fork is leveled when unloading. When loaded, the fork may not be leveled even the indicator lamp is lit because of the flexion of forks.

► For safe operation of laser pointer

Read and understand following cautions.



Check the focus of the laser beam before operation. If it is out of focus, contact your local Nichiyu dealer for adjustment.



Do not sprinkle water to the laser pointer.



Do not use the laser pointer on a slope. Then, it cannot detect the correct position.



Explain precautions about the laser beam to people who work around the forklift truck.



The laser beam is just a reference. Operator has to make sure visibly when inserting forks into a pallet.



The laser light is dangerous when eyes are exposed directly. Do not see the beam directly. Do not see the reflected beam by mirror also.



Do not disassemble or modify the laser unit.



Do not use this device in the place where any abnormality or incorrect activation of machines have experienced or expected by the laser beam.

► Name of each part

Switch for the laser pointer

To power on the laser pointer, turn the switch lever up. When the fork is leveled, the laser pointer irradiates the laser beam and the fork leveling indicator lamp is lit.

To power off, turn the lever down.

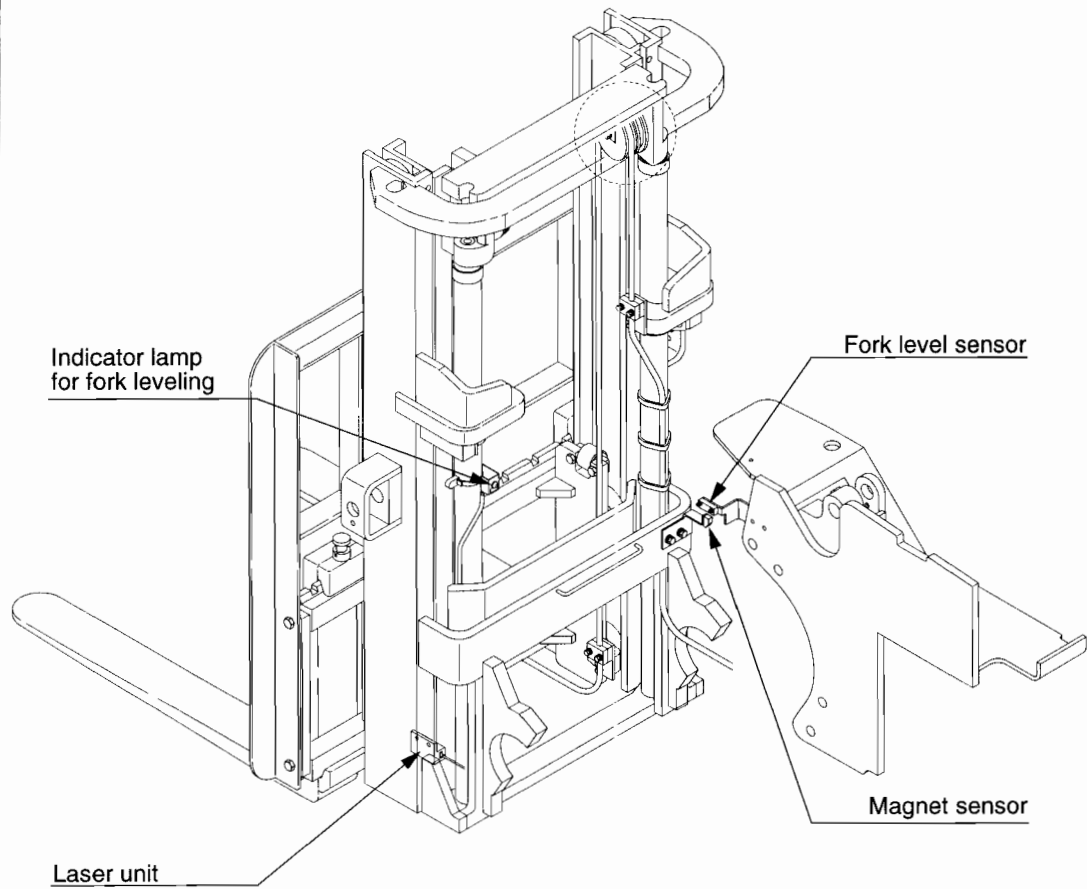
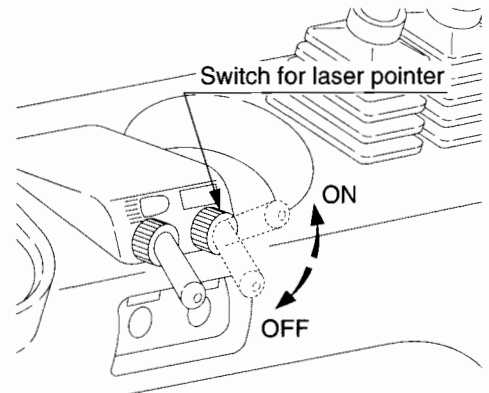

► General information for the laser pointer



The LASER POINTER has the laser unit (semiconductor laser) in it. The laser is classified by the output power of the beam. Observe the following precautions.



The laser beam is very danger when it is irradiated to eyes.

- Do not see the source of light.
- Do not irradiate the beam to eyes directly.
- Do not irradiate the beam to animals.
- Do not see the beam even reflected.



If saw the laser beam directly, avert eyes from it immediately. The category of the laser unit in the LASER POINTER is Class 2. Under this laser class, eyes are protected by winking several times.

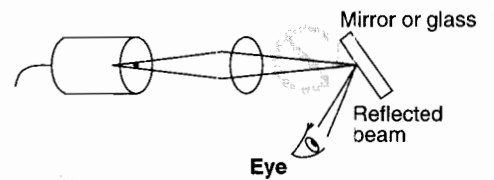
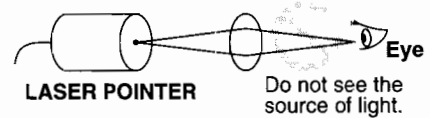

 means prohibited action.

Classification of laser

The laser unit is classified by output power for evaluation of risk. The classification is as follows.

Classification	Evaluation for danger
Class 1	No effect on human body.
Class 2	Eyes are protected by repugnant reaction such as winking.
Class 3A	Eyes are protected by repugnant reaction such as winking, but direct watching of the laser beam by an optical way is dangerous.
Class 3B	Direct watching of the laser beam is dangerous.
Class 4	High risk is expected for eyes to damage by the laser beam even diffused reflected. Skin damage or source of ignition also may be possible.



The category of the laser unit in the LASER POINTER is Class 2.

Regarding to affections from or to the LASER POINTER with other equipment

- (1) **Affection to equipment that uses infrared rays**
The wave length of the LASER POINTER (semiconductor laser) is 650 nm, and the general infrared rays are around 800 nm. So, it may not affect each other.
- (2) **Affection to wireless equipment, OA equipment and/or AGV (Automatic Guided Vehicle)**
The laser beam is a lay of light which does not produce electromagnetic noise. So, it does not affect for radio waves.
- (3) **Affection to LASER POINTER from high-tension line or strong electric noise.**
The weak point of the semiconductor laser is the surge (abnormal voltage) that is created by its high-speed response, and high temperature. The LASER POINTER is designed to protect from such circumstances. However, the arc-welding and/or induction noise from a high-tension line is bad for the LASER POINTER, and it may be affected under these circumstances. Therefore, the using place should be made sure not to affect to it. Leaving under direct sunshine in summer is caused high temperature and may shorten the lifetime or damage the laser unit.



The safety precautions of the laser beam shall be explained to operators and other workers around a forklift truck.



Do not use this device in the place where any abnormality or incorrect activation of machines have experienced or expected by the laser beam.



Modification prohibited

- Do not disassemble, modify and/or adjust a potentiometer of the LASER POINTER. They are very dangerous.
- Do not watch a source of light even if not irradiated the beam.
- Do not replace with other similar device for the LASER POINTER.

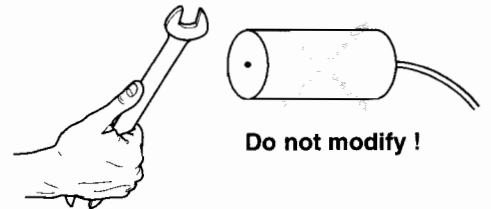

3

DRIVING AND OPERATION



- Do not operate the forklift truck prior to daily inspection.
- Inspect the forklift truck before you operate it to be sure that it is properly maintained and in good working order.

■ Preparation of start

- 1) Check the directional lever is in the neutral position and the parking brake is applied.

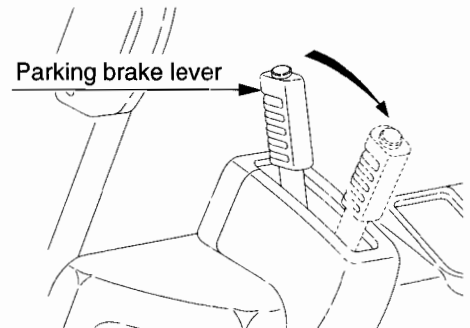
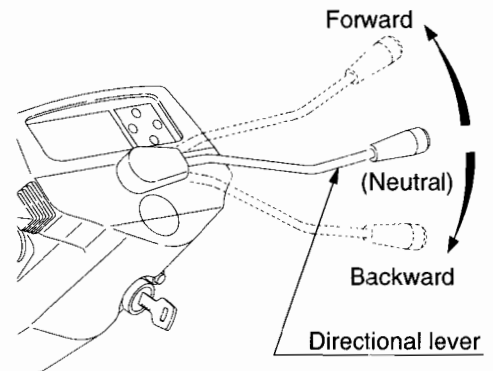

- 2) Turn on the key switch

Grasp the steering wheel knob and then turn on the key switch.

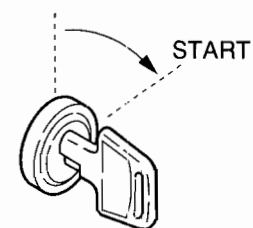

- 3) Tilting back the mast ass'y.

- Raise the forks about 150 to 200mm from the floor by the lift lever.
- Tilt back the mast ass'y by the tilt lever.

Automatic power off function :

- Suspending the travel and hydraulic operation for 15 minutes, electric circuit is turned off automatically. Turn the key switch into the [START] position to turn the power on again.

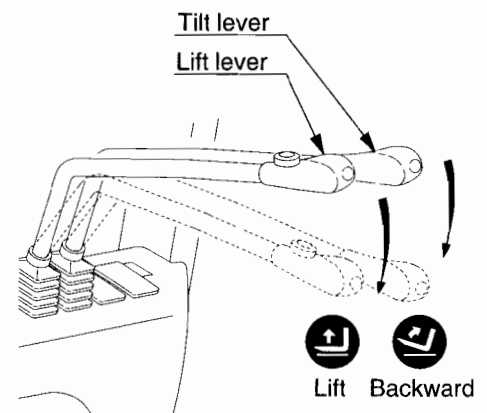

4) Operation of the directional lever

Operate the directional lever to the moving direction.
 Forward : Push the lever forward.
 Backward : Pull the lever backward.

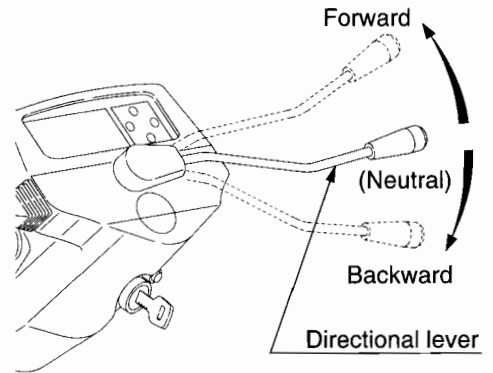

5) Release the parking brake

Depress the brake pedal.
 Push the parking brake lever forward fully to release the parking brake.
 Grasp the steering wheel knob by the left hand, put the right hand lightly on the steering wheel.

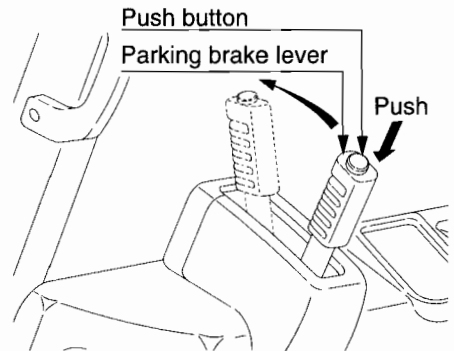

Traveling

1) Start

Release the brake pedal and depress the accelerator pedal gradually, then the lift truck will begin to move.
 Acceleration varies in accordance with the depressing of the accelerator pedal.

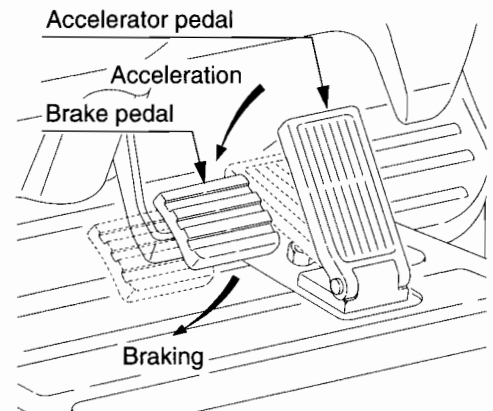

Do not start or stop the lift truck suddenly.

2) Turning



Slow down and operate steering wheel carefully and check to make sure the tail swing area is clear before turning.

3) Electrical brake (Plugging brake)

While traveling, if the directional lever is shifted in opposite position, the electrical brake should be activated.
 Braking force varies in accordance with the depressing of the accelerator pedal.

4) Stop

Slow down and apply the brake gradually. Do not apply brake suddenly.



Do not apply brake suddenly.

**5) Parking**

When parking the lift truck,

- When getting off the lift truck, correctly apply the parking brake lever.
- Tilt the mast to forward and lower the forks on the floor.
- Do not park the lift truck on a slope.
- When leave the lift truck, remove the key.



■ Stacking operation



**Check the following items before operating forklift truck.
Make sure that operating area is clear.**

When stacking a load, observe the following procedures.

- ① Slow down the travel speed.
- ② Stop in front of the stacking place.
- ③ Check for safety around the stacking area.
- ④ Face the forklift truck square to the stacking place.
- ⑤ Tilt the mast assembly to the vertical position.
- ⑥ Lift up the forks above the stacking position.

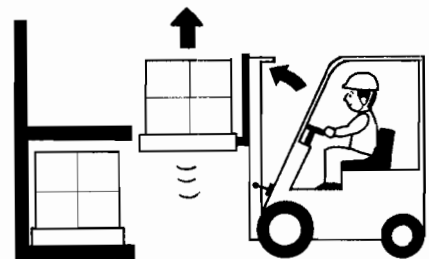

- ⑦ Check the stacking position. Move forward slowly and stop at the proper position.



- ⑧ Make sure the load is just above the stacking position, and lower the forks slowly. Make sure the load is stacked correctly.



When the load is not aligned at front or rear ends:

- 1) Lower the forks until that the load is put on the shelf and the forks are free.
- 2) Move backward about 1/4 length of the forks.
- 3) Lift (50-100mm) the forks again and move forward to align the load.
- 4) Lower the load slowly for proper stacking.



- ⑨ Check the clearance of rear side and move backward slowly.
- ⑩ Make sure the tips of the forks are off the load or pallet, and lower the forks to the traveling position (150-200mm above the floor).

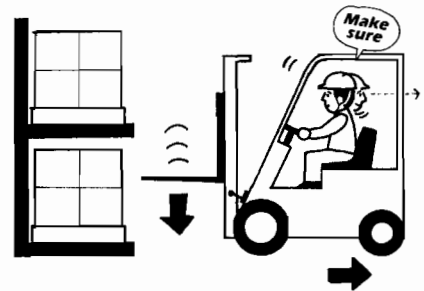

■ Picking operation

When picking the loads, observe the following procedures.

- ① Slow down the traveling speed.
- ② Stop in front of the load (about 300mm between the load and the fork tips).
- ③ Make sure the lift truck is square with the load.
- ④ Check for safety around the picking area.
- ⑤ Tilt the mast assembly to the vertical position.
- ⑥ Lift the forks to the inserting position.

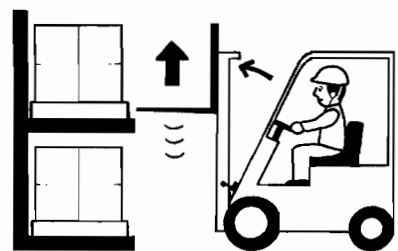

- ⑦ Check the inserting position.
- ⑧ Move forward until the forks are fully inserted into the load.

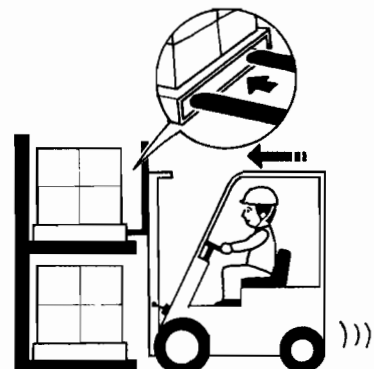

When it is difficult to insert the forks fully into the pallet:

- 1) Insert about 3/4 length of the forks and lift up the pallet (50mm-100mm).
- 2) Pull the pallet out about 100-200mm.
- 3) Lower the pallet again on the shelf, and insert the forks fully into the pallet.

- ⑨ After inserting the forks, lift up the pallet about 50-100mm.
- ⑩ Slowly retract the mast completely.
- ⑪ Check the clearance of rear side and move backward slowly until clear the lowering space of load.

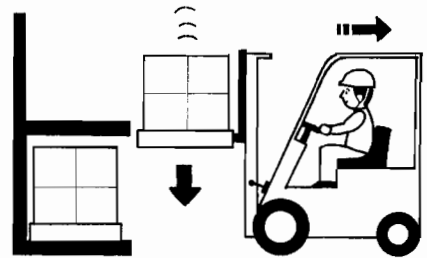

- ⑫ Lower the load to the position for traveling.(150-200mm above the straddle legs.)
- ⑬ Tilt the forks all the way up to stabilize the load.

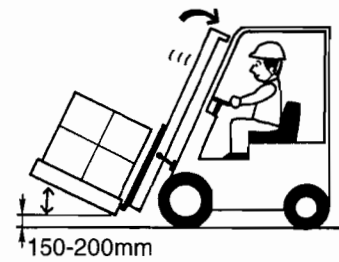

- ⑭ Carry the load to its destination.

■ How to use the laser pointer (Option)

When the optional laser pointer is equipped on your truck, follow this instruction for safe and effective operation.

To power on the laser pointer, turn the switch lever up. When the fork is leveled, the laser pointer irradiates the laser beam and the fork leveling indicator lamp is lit.

To power off, turn the lever down.

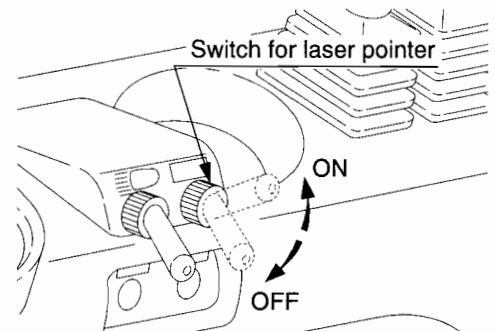

■ Picking operation of the load

Follow the next procedure to pick the load.

Turn on the power switch of the laser pointer on the front hood.



The laser light is dangerous when eyes are exposed directly. Turn off the switch of the laser pointer when not use.

- ① Slow down the traveling speed when approaching the load to pick up.
- ② Stop in front of the load. (about 300 mm between the load and the fork tips)
- ③ Make sure the lift truck is square with the load.
- ④ Check for safety around the picking area.
- ⑤ Tilt the mast to the vertical position. Then the laser pointer is lit automatically.



The laser pointer is lit when the forks are leveled. The fork level indicator lamp is also lit then. If the laser pointer and fork level indicator lamp are not lit, make sure if the power switch is turned on.



The fork level indicator lamp indicates that the fork is leveled when unloading. When loaded, the fork may not be leveled even the indicator lamp is lit because of the flexion of forks.

- ⑥ Lift the forks to the inserting position. Stop forks when the laser light is reached to the center of the girder of the pallet.



In the case of the dot type, the laser dot should light to the upper board of the pallet when the fork is in the inserting position.

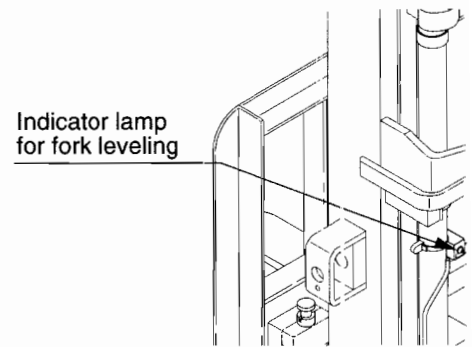
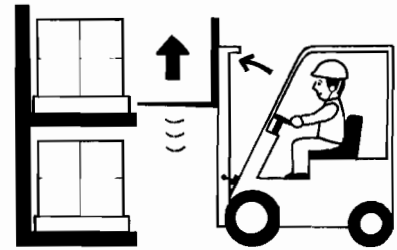

Laser beam
(Dot type)

Laser beam
(Line type)

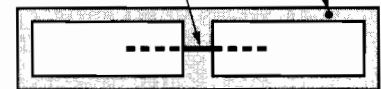

- ⑦ Check the inserting position. Then, move forward until the forks are fully inserted into the pallet. If the forks push the pallet, make sure the inserting position again.



If it is difficult to insert the forks fully into the pallet:

- 1) Insert about 3/4 length of the forks and lift up the pallet 50 to 100 mm, and pull it out about 100 to 200 mm. Then, lower it again on the shelf.
- 2) Insert the forks again into the pallet.

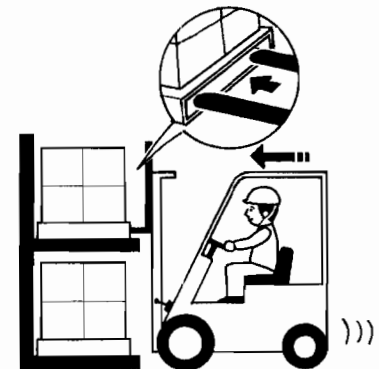

- ⑧ After inserting the forks, lift up the pallet about 50 to 100 mm.
- ⑨ Check the clearance of rear side and move backward slowly to the clear space to lower the pallet.
- ⑩ Lower the pallet to the position for traveling. (150 to 200 mm above the floor)
- ⑪ Tilt the forks all the way up to stabilize the load.
- ⑫ Carry the load to its destination.
- ⑬ Turn off the power switch of the laser positioner after picking operation.

■ Battery

- This section explains NICHYU's genuine battery and charger.
- When the lift truck is equipped with another type battery and/or charger, please follow the instructions provided by that manufacturer.

▶ Keep away from fire (Explosive gas)

- Never allow open flame to come near the battery.
- Explosive gas is always present in the battery.
- Smoking, flames, or sparks will result in battery explosions.

**▶ Pay attention to an electric shock**

**Do not make a short circuit.
The battery has high voltage and power.**



When servicing the battery, wear the safety goggles, rubber gloves and boots.

▶ Connect correctly

Do not swap the positive and negative terminals.

- It can cause sparking, burning and/or explosion.

▶ Keep tools away

Keep tools away from terminals to avoid sparks or shorting.

► Do not over-discharge



Do not use the forklift truck until no longer run, it will shorten the battery life.

- When the battery discharge indicator shows empty, charge the battery as soon as possible.

► Keep clean



- Keep the upper surface of the battery clean.
- Do not use a dry cloth when cleaning, as it may produce static electricity.
- Wear the safety goggles, rubber gloves and boots.



Clean the battery before charging.

► Wear safety clothes



Wear safety goggles, rubber gloves and boots to protect yourself.

► Be careful the electrolyte



Be careful the electrolyte does not touch the skin.

- Electrolyte of the battery is sulfuric acid.



▶ Emergency first aid



The battery contains sulfuric acid which causes severe burns if touched.

If an accident occurs, receive emergency first aid and consult your physician immediately.

- Spilled on skin:
Wash down with water for 10 to 15 minutes.
- Splashed in eye:
Wash down with water for 10 to 15 minutes.
- Swallowed:
Drink large amounts of milk or water.
- Splashed on clothes:
Take off clothes immediately.

If you do not follow these instructions, you will be seriously injured or killed.

▶ Close vent caps securely



Make sure all vent caps are closed securely. Failure to close the caps can cause leaking of electrolyte.

▶ Washing



Do not wash the battery on the forklift truck. It causes damage to the truck.

▶ Abnormal battery



If the battery shows the following situation, contact NICHYU's qualified service facility or battery manufacturer.

- The battery stinks.
- The electrolyte is muddy.
- The electrolyte decreases fast.
- The temperature of electrolyte is too high.

▶ Do not disassemble the battery.



Do not drain the electrolyte, disassemble and repair the battery.

► Storage



- When storing the battery, store in a well-ventilated and dry place.
- Keep the battery away from open flames or ignitions.

► Do not dispose of used batteries.



Please contact NICHYU's qualified service facility or the battery manufacturer for disposal.

■ Precautions for charging the battery

► Check electrolyte level



Do not use the forklift truck if the electrolyte level is low.

- Failure to keep proper level of the electrolyte can cause overheating or burning of the battery and electrical components of the forklift truck.
- Check electrolyte level once a week. If the level is low, add distilled water to the specific level.

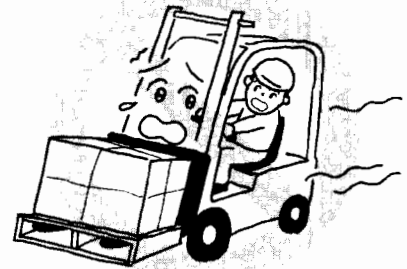

► Do not over-charge.



Do not over-charge the battery.

► Pay attention to an electric shock



Do not touch the terminal or transformer when charging.

- The charger has high voltage and power when working.

► Charge in well-ventilated areas.



- Charge batteries only in approved and well-ventilated areas.
- Explosive gas comes out of the battery while charging. If you use the local supply charger, follow its manufacturer's instruction.



► **Check cable and plug**



Prior to charging, check the condition of the cable and plug.



Do not charge the battery if cable or plug is damaged.

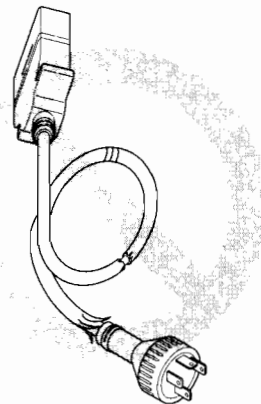

► **Check specific gravity**



Measure the specific gravity of all cells before charge.

- The abnormality of the battery may be found by comparing of the specific gravity before and after charging.
(Refer the section "Reading of specific gravity")

► **Interruption of charge**



- When interrupting the charge, push the STOP button of the charger before disconnecting plugs.
- Failure to observe this instruction can cause a hazardous electrical shock or explosion of the battery by sparking.

► **Kinds of charge**

- There are three kinds of charge. These charges are a normal charge, a balancing charge and a supplementary charge.
- Charging time depends on the discharging condition and capacity of the battery.
- Generally, 8 to 10 hours are required to charge the battery fully.

Classification	Application
Normal charge	After daily operation or when the "E" segment of the battery discharge indicator is lit.
Blancing charge	Every two weeks (Check electrolyte level and specific gravity)
Supplementary charge	In a recess
Charge for storage	Carry out the blancing charge before storing the battery for an extended time. (Periodical charge for every 15 to 30 days during storage is recommended.)

■ Charger



Use the same value of a fuse for replacement.
If you need to replace the fuse for the charger,
disconnect all input and output plugs first.



The supplied voltage should be stabilized with-
in $\pm 10\%$ of the rated input voltage.



The charger should be used within 0°C to
 $+ 40^{\circ}\text{C}$ ambient temperature.
If the temperature is 40°C or above, the charger
may be overheated.



The charger shall be protected from the mois-
ture such as rain and snow.
Failure to do so can cause an electrical short
and/or fire.



Do not use the charger for other purpose.
The charger is designed to charge the battery
for the forklift truck.



Inspect plugs and cables of the charger period-
ically.
If you find any damages, do not use the charger
until it is repaired.



The ground cable shall be connected.
Otherwise, an electrical shock hazard may be
caused.



Do not disassemble or modify the charger.



Do not use the charger continuously to charge
some batteries in turn.
The continuous use can cause overheating,
and the charger may be damaged.



Do not connect the charger plug to the chassis plug of the forklift truck.

- This may damage the forklift truck or the charger.

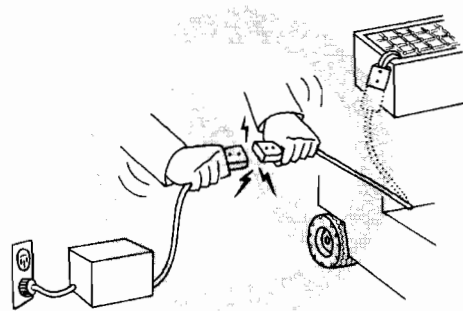

The charger plug (from the charger) must be connect to the plug of battery side securely.

- Insecure connection may overheat or get fire on the charger.

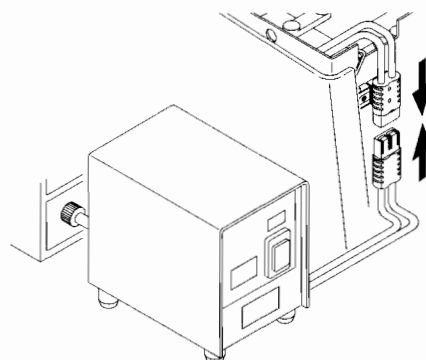

■ How to charge the battery (By built-in charger)

▶ Built-in charger (Option)

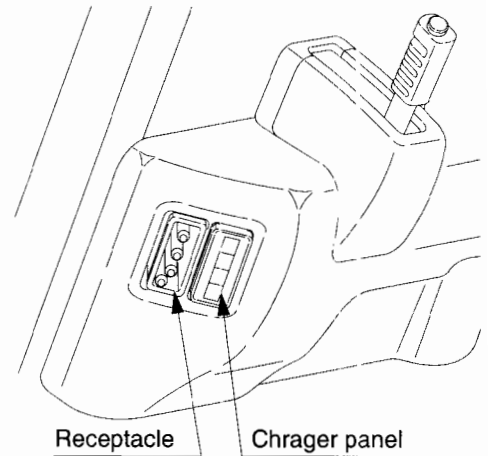

▶ Charger panel

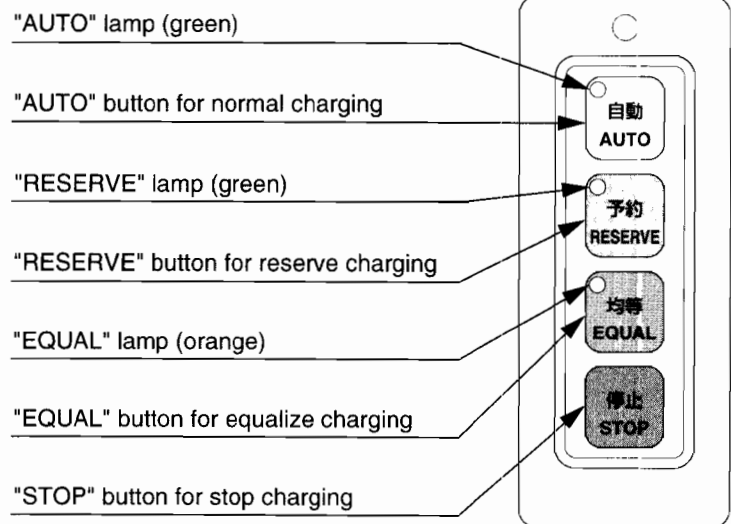

► **Normal (Daily charge)**

This charge returns the battery to a full-charged condition after operating the forklift truck.

○ **Built-in charger (Option)**

- ① Move the forklift truck to designated charging area.
- ② Turn off the key switch and remove the key.

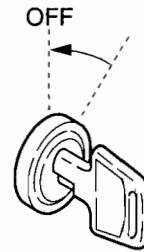

[How to open the battery cover of FB10P-28P.]

Release the bonnet catch and open the battery cover.

Gas spring (assist damper with self locking) is used at the battery cover. Make sure the condition of locking.

Make sure that the locking pin is secured in the hole.

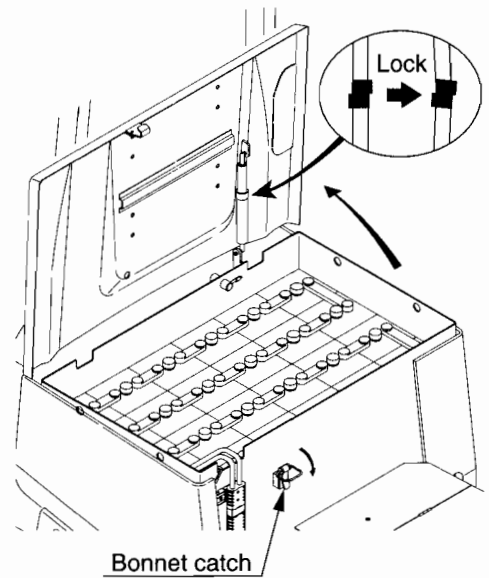

[How to open the battery cover of FB30P.]

Release the bonnet catch and open the battery cover.

Do not release the lock at the top of the battery cover.

Gas spring (assist damper with self locking) is used at the battery cover. Make sure the condition of locking.

Make sure that the locking pin is secured in the hole.

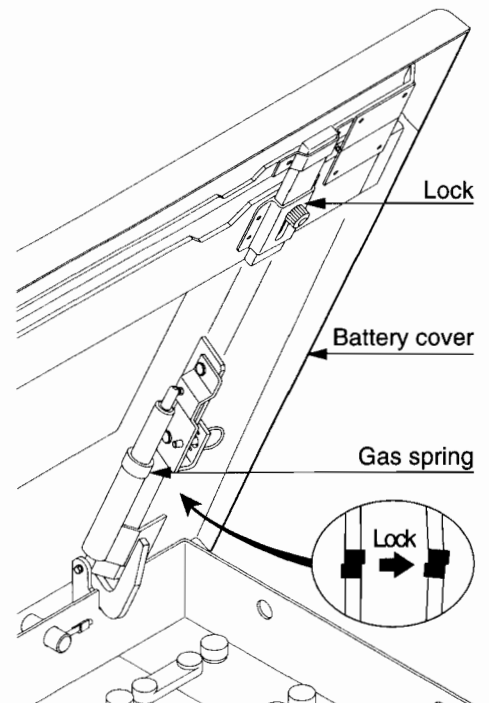

[How to open the battery cover of FB35PJ.]

Release 2 bonnet catches. And open the battery cover ① fully as the gas spring is locked.



The battery cover may hit to the steering wheel when they are opened. Adjust the steering position forward and the seat position backward before opening the battery cover.



Gas spring (assist damper with self locking) is used at the battery cover. Make sure the condition of locking.



Make sure that the locking pin is secured in the hole.

Pull the battery cover ② to open.

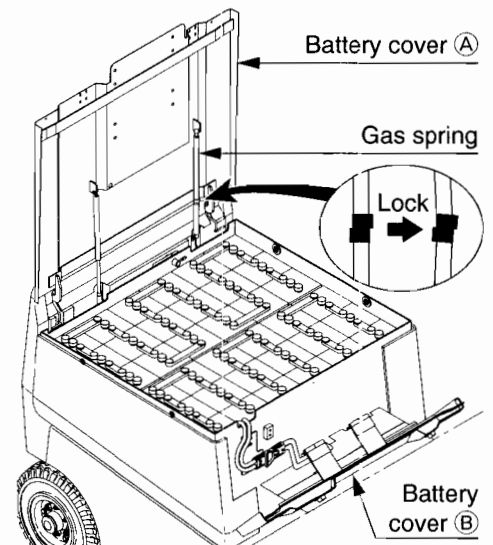
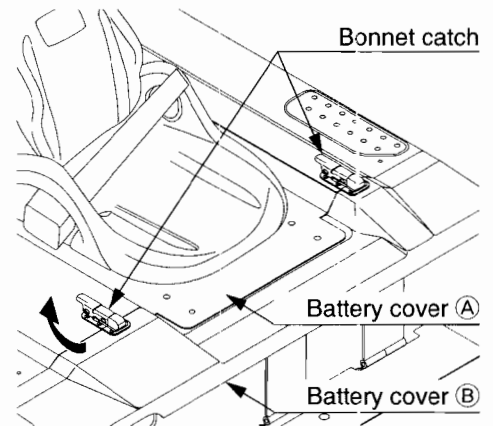

- ③ Connect the rectangular plug of the AC cable to the receptacle on the charger panel.
- ④ Connect the AC plug to wall outlet.

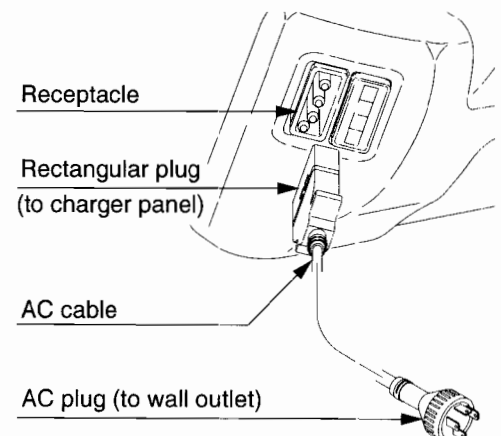

Then, all "AUTO", "RESERVE" and "EQUAL" lamps are turned on.



If these lamps are not turned on, make sure the AC cable is connected correctly.

- ⑤ Push "AUTO" button.
- ⑥ The "AUTO" lamp (green) is lit. Both "RESERVE" and "EQUAL" lamps are turned off.

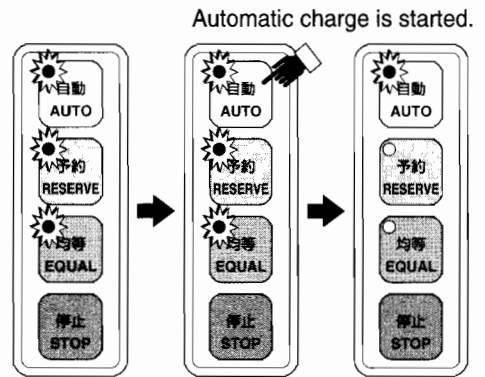

When starting to charge the battery, the display on the truck is turned on and shows the charging status on the battery discharge indicator.

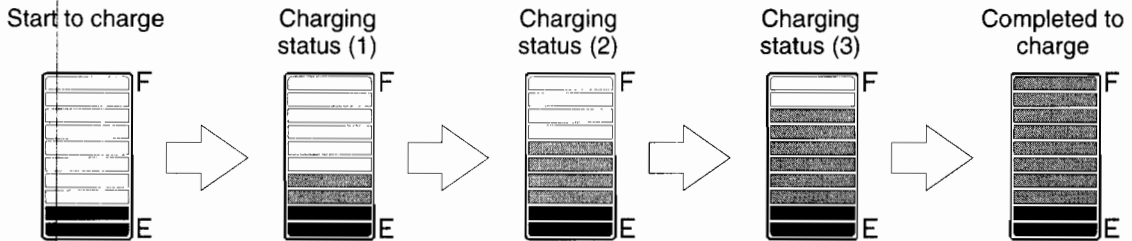

- ⑦ When charging is completed, the message of "CHARGE COMPLETION" is shown on the display.
- ⑧ When the "STOP" button on the charger is pushed or the charging cable is disconnected, this message is disappeared.

Charge completion screen

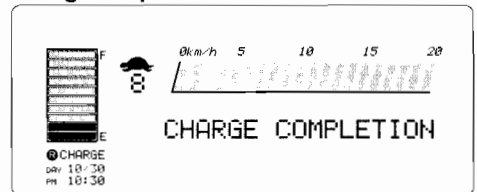

"TIME UP" screen

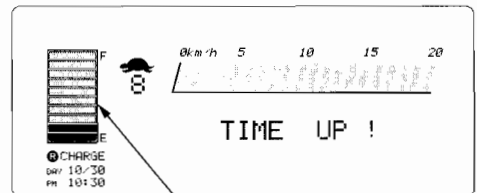

The gauge of the battery discharge indicator is flashed.



- If the charging is not completed within 16 hours, the message of "TIME UP !" is shown on the display to show abnormal completion.
- This message is disappeared when disconnecting the charger cable.



- If the power supply is shut off while charging the battery, the display is turned off once. If the power is recovered within one hour, the charging will be started again with display. If the power is not recovered within one hour, the charging will not be started and completely shut off. (The display is turned off either.)
- After completion of the normal charging of the battery, if the charger cable is not disconnected for more than 44 hours, the supplementary charging will be started if the ambient temperature is less than 5 °C. In this case, the charging status is shown on the display again.

- ⑨ Disconnect the rectangular plug and AC plug.
- ⑩ Push the yellow stopper at the center of the gas spring and close the battery cover.



Be careful not to pinch hands or fingers between battery cover and case.

- ⑪ Apply the bonnet catch after closing the battery cover.

Closing battery cover

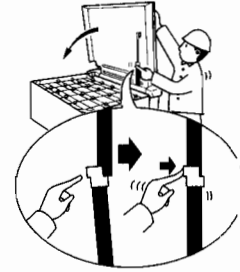

- Do not disconnect the rectangular plug, AC plug and battery plug while charging.
- Do not operate any hydraulic valve levers or accelerator pedal while charging.
- Push the "STOP" button when discontinue to charge.



Do not touch any parts of charger and cable by wet hand.

- The charger operates with high voltage. Touch by wet hand may cause electrical shock.

► Reserve charge

This function is the timer to start charging of the battery. If you want to start charging after a while, or a few days later, for example, this is very convenient function. This function can charge the battery as the "AUTO" mode only.

● Setting of the starting time

- If any operation of traveling or hydraulics are done while setting the timer, the setting screen is returned to the normal screen immediately.
- This setting cannot be activated while traveling and depressing the brake pedal.



① Move the forklift truck to appropriate area and park.

② Push the "B" button of the mode select switch to get the reserve charge setting screen. (If pushing "MODE" button, the screen returns to the normal.)
The reserve charge setting screen appears when the AC cable is connected to the charger panel also.

③ Push "<" or ">" button to select "DATE" or "EVERY DAY".

Normal screen

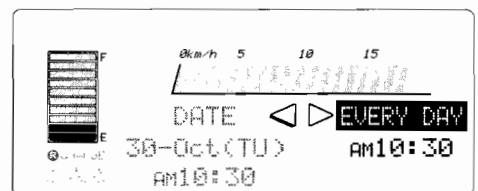
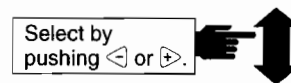
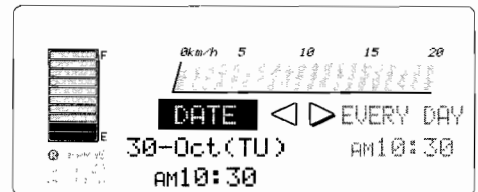
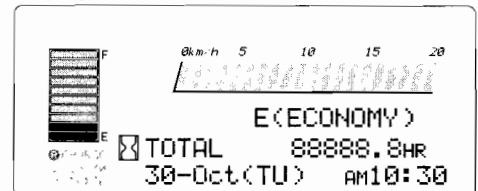

When selecting "DATE"

The reserved time is revised automatically to the same time of seven (7) days later after expiring it.
It is convenient to charge the battery every weekend.

When selecting "EVERY DAY"

The reserved time is revised automatically to the same time of the next day after expiring.
It is convenient to charge the battery everyday.



The displayed time is the starting time of charge. It is not the finishing time of charge.

□ In case of setting of "DATE"

Select "DATE" by pushing "◀" or "▶".

Screen displays the current setting. (or no date is displayed if not set before.)

Push "Ⓑ" button to move the cursor to the month.

Push "MODE" button to get the normal screen.



When setting the mode of next ① to ⑤, each button works as below.

- "◀" and "▶" buttons : Move the cursor to select the value.
- "Ⓑ" button : Move the cursor to the next item.
- "MODE" button : Back the cursor to the previous item.

① Set the month

Push "◀" or "▶" button to set the month.

After setting of the month, push "Ⓑ" button to select the date.

If pushing "MODE" button, the cursor is returns to the "DATE" or "EVERY DAY" area.

② Set the date

Push "◀" or "▶" to select the date. The day of the week is displayed automatically by setting the date.

After setting the date, push "Ⓑ" button to move the cursor to the time (AM or PM).

If pushing "MODE" button, the cursor is returned to the month area.

③ Set the AM or PM

Push "◀" or "▶" to select "AM" or "PM".

After the setting, push "Ⓑ" button to move the cursor to the hour.

If pushing "MODE" button, the cursor is returned to the data area.

"DATE" screen

"DATE" is flashed.

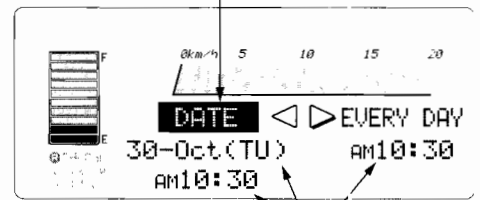

Displays the current setting.

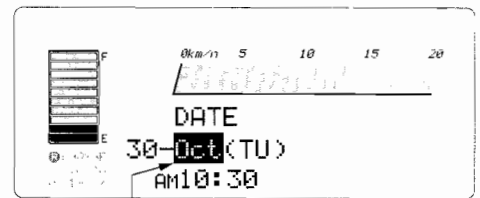

Set "Month"

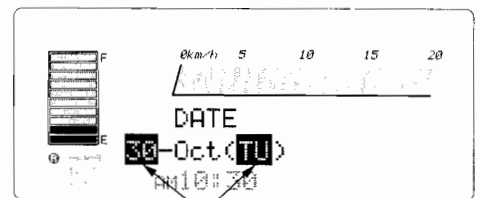

Set "Date". "Day of the week" is displayed automatically by entering the date.

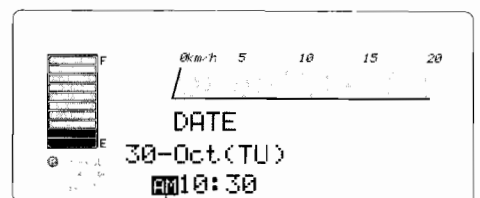
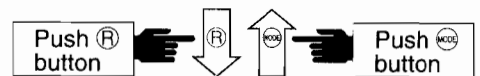

Select "AM" or "PM".



④ Set the hour

Push “←” or “→” to change the hour. Hour can be selected from 1 through 12.
 After setting the hour, push “R” button to move the cursor to the minute.
 If pushing “MODE” button, the cursor is returned to the AM or PM area.

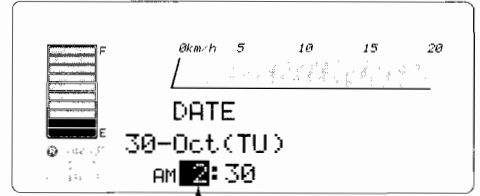

Set the hour

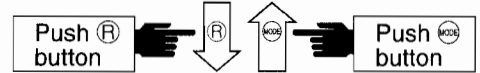

⑤ Set the minute

Push “←” or “→” to set the minute. The minute can be set to “00”, “15”, “30” or “45”.
 After setting, push “R” button. Then, “COMPLETE” sign is flashed three times and the display returns to the normal screen.
 If pushing “MODE” button, the cursor is returned to the hour area.

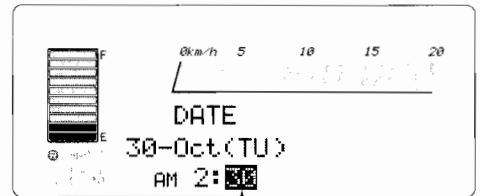

Select the minute.

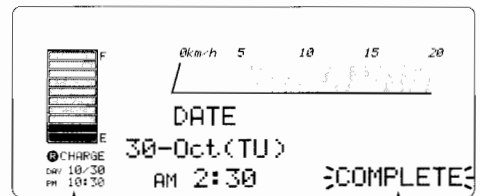

Reserved date and time is displayed.

“COMPLETE” is flashed three times.

Return to the normal screen.

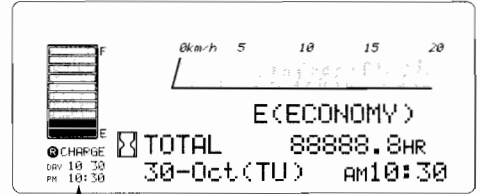

Reserved date and time is displayed.



Make sure that the reserved date and time which are displayed at the left lower corner of the screen is correct.



• The past date and time cannot be set.

Example

Current time 30-Oct (TU), 2003, PM10:30
 ↓
 Input date and time 30-Oct (TU), PM10:00
 ↓
 Reserved setting 30-Oct (TU), 2004, PM10:00

If input the past date and time, it is memorized as the same date and time of the next year.

* If the reserved date and time is become past by setting the current date and time, the same situation is occurred.

• The reservation is invalid if all required data are not entered.

Example : Input data 30-“blank” (TU), PM10:30 ⇒ invalid

If any data is not entered (blanked) and move to the next step, all data in that screen will be invalid and deleted.

□ In case of setting of "EVERY DAY"

Push " \leftarrow " or " \rightarrow " to select "EVERY DAY". The screen displays the current setting. If not set before, no data are displayed.

Push " R " button to move the cursor to AM/PM.

Push " MODE " button to return to the previous screen.



When setting the mode of next ① to ③, each button works as below.

- " \leftarrow " and " \rightarrow " buttons : Move the cursor to select the value.
- " R " button : Move the cursor to the next item.
- " MODE " button : Back the cursor to the previous item.

① Set the AM or PM

Push " \leftarrow " or " \rightarrow " to select "AM" or "PM".

After selecting, push " R " button to move the cursor to the hour.

If pushing " MODE " button, the cursor is returns to the "DATE" or "EVERY DAY" area.

② Set the hour

Push " \leftarrow " or " \rightarrow " to set the hour. The hour can be set from 1 through 12.

After setting, push " R " button to move the cursor to the minute.

If pushing " MODE " button, the cursor is returned to the AM or PM area.

③ Set the minute

Push " \leftarrow " or " \rightarrow " to set the minute. The minute can be set to "00", "15", "30" and "45".

After setting the minute, push " R " button. Then, "COMPLETE" sign is flashed three times and return to the normal screen.

If pushing " MODE " button, the cursor is returned to the hour area.

"EVERY DAY" screen

"EVERY DAY" is flashed.

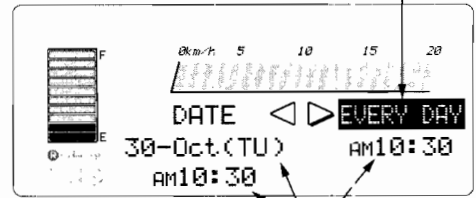

Displays the current setting.

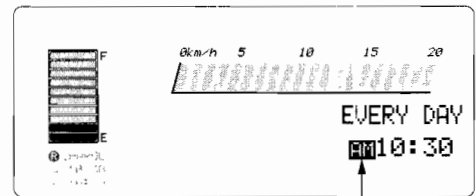

Select "AM" or "PM".

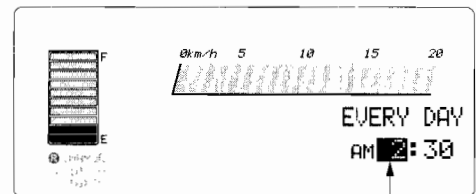
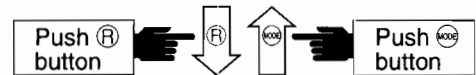

Select the hour

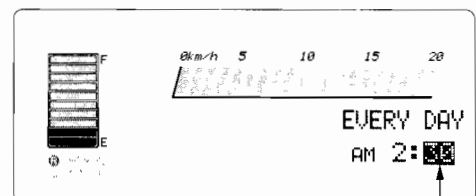

Select the minute





Make sure that the reserved date and time which are displayed at the left lower corner of the screen is correct.



• The past time cannot be set.

Example

Current time 30-Oct (TU), 2003, PM10:30
 ↓
 Input date and time PM10:00
 ↓
 Reserved setting 31-Oct (FR), 2003, PM10:00

If input the past time, it is memorized as the same time of the next day.

* If the reserved time is become past by setting the current date and time, the same situation is occurred.

• The reservation is invalid if all required data are not entered.

Example : Input data PM-"blank" : 00 → invalid

If any data is not entered (blanked) and move to the next step, all data in that screen will be invalid and deleted.



After the completion of the reserve setting, its data is renewed automatically after the past of its time.
 In case of "EVERY DAY", it is renewed to the same time of the next day.
 In case of "DAY", it is renewed to the same time of seven (7) days later.

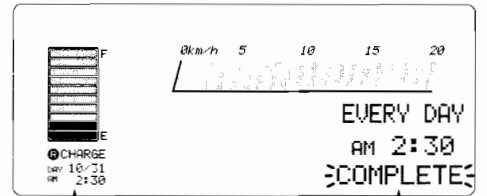

Reserved date and time is displayed.

"COMPLETE" is flashed three times.

Return to the normal screen.

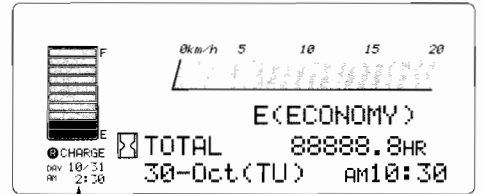

Reserved date and time is displayed.

○ Reserve charge

This mode starts to charge the battery by the preset date and time.

- ① Move the forklift truck to designated charging area.
- ② Turn off the key switch and remove the key.



[How to open the battery cover of FB10P-28P.]

Release the bonnet catch and open the battery cover.



Gas spring (assist damper with self locking) is used at the battery cover. Make sure the condition of locking.



Make sure that the locking pin is secured in the hole.

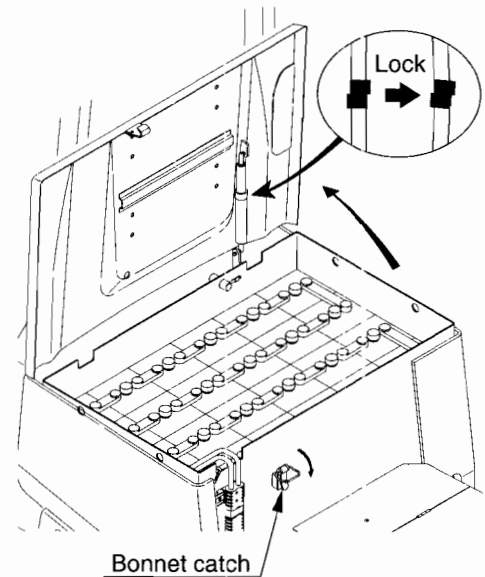

[How to open the battery cover of FB30P.]

Release the bonnet catch and open the battery cover.



Do not release the lock at the top of the battery cover.



Gas spring (assist damper with self locking) is used at the battery cover. Make sure the condition of locking.



Make sure that the locking pin is secured in the hole.

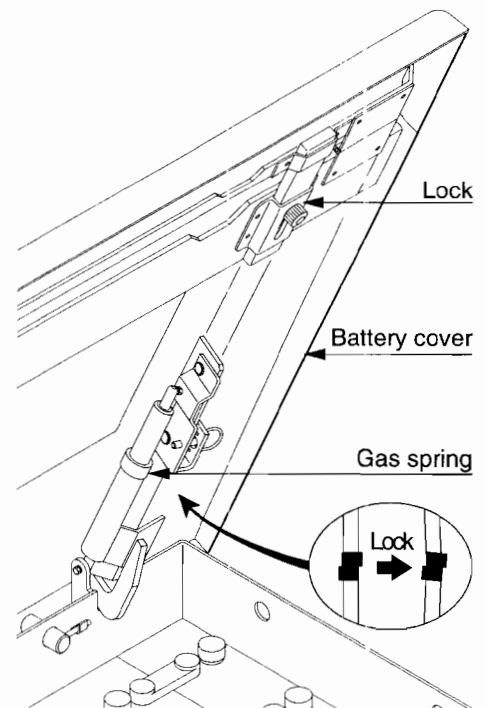

[How to open the battery cover of FB35PJ.]

Release 2 bonnet catches. And open the battery cover ① fully as the gas spring is locked.



The battery cover may hit to the steering wheel when they are opened. Adjust the steering position forward and the seat position backward before opening the battery cover.



Gas spring (assist damper with self locking) is used at the battery cover. Make sure the condition of locking.



Make sure that the locking pin is secured in the hole.

Pull the battery cover ② to open.

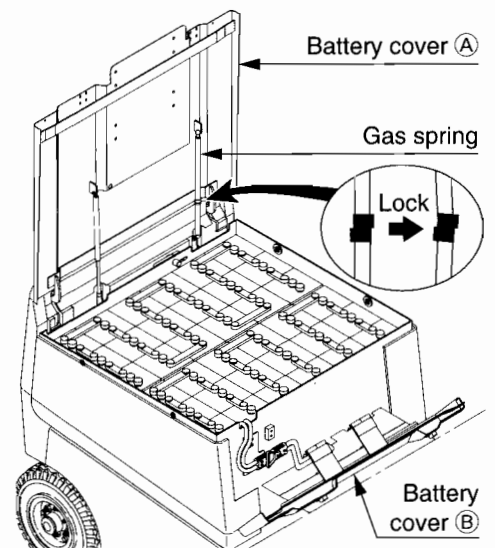
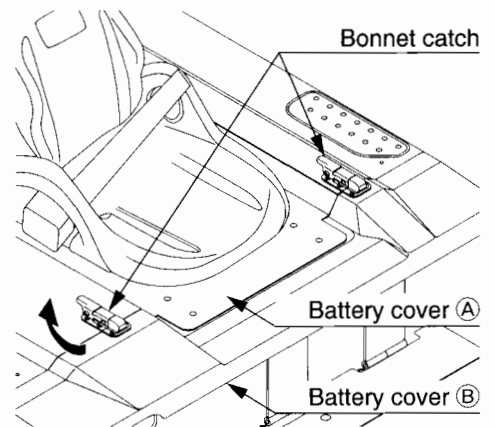

- ③ Connect the rectangular plug of the AC cable to the receptacle on the charger panel.
- ④ Connect the AC plug to wall outlet.

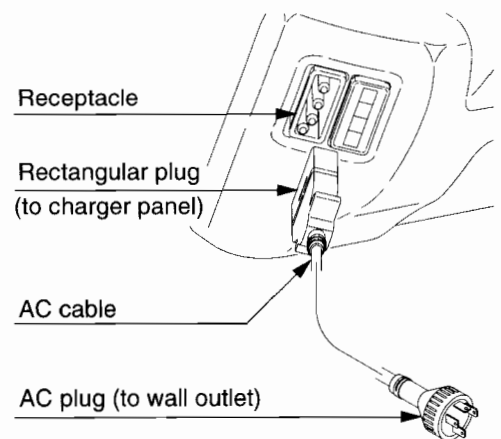

Then, all "AUTO", "RESERVE" and "EQUAL" lamps are turned on.



If these lamps are not turned on, make sure the AC cable is connected correctly.

- ⑤ Push "RESERVE" button.
- ⑥ The "RESERVE" lamp (green) is lit. Both "AUTO" and "EQUAL" lamps are turned off.

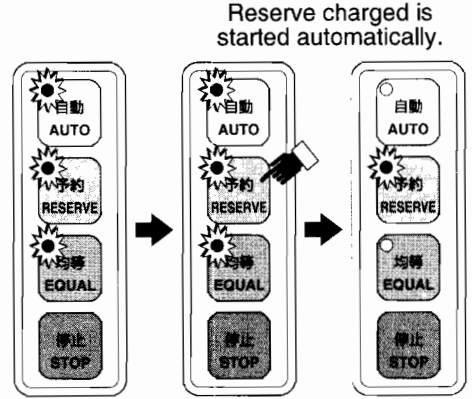

When starting to charge the battery, the display on the truck is turned on and shows the charging status on the battery discharge indicator.

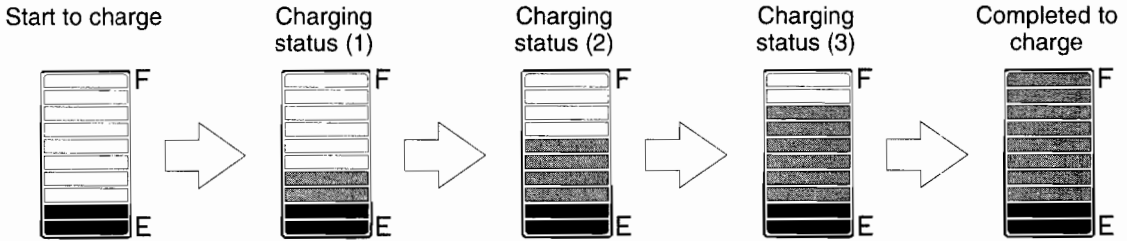

- ⑦ When charging is completed, the message of "CHARGE COMPLETION" is shown on the display.
- ⑧ When the "STOP" button on the charger is pushed or the charging cable is disconnected, this message is disappeared.

Charge completion screen

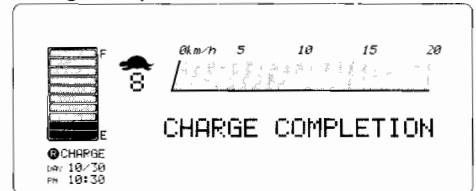

- If the charging is not completed within 16 hours, the message of "TIME UP !" is shown on the display to show abnormal completion.
- This message is disappeared when disconnecting the charger cable.

"TIME UP" screen

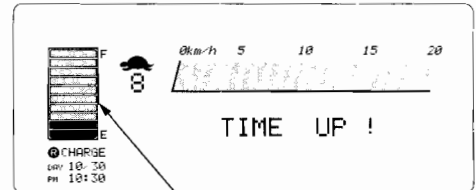

The gauge of the battery discharge indicator is flashed.



To cancel the reservation, push the "STOP" button on the charger panel. To change the reservation, push the "RESERVE" button on the charger panel.

- ⑨ Disconnect the rectangular plug and AC plug.
- ⑩ Push the yellow stopper at the center of the gas spring and close the battery cover.



Be careful not to pinch hands or fingers between battery cover and case.

Closing battery cover

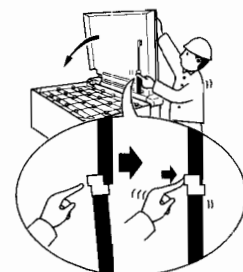

- ⑪ Apply the bonnet catch after closing the battery cover.



- Do not disconnect the rectangular plug, AC plug and battery plug while charging.
- Do not operate any hydraulic valve levers or accelerator pedal while charging.
- Push the “STOP” button when discontinue to charge.



Do not touch any parts of charger and cable by wet hand.

- The charger operates with high voltage. Touch by wet hand may cause electrical shock.

► Balancing charge

Specific gravity of electrolyte in each cell becomes unbalanced after a certain time of charge. In this case, charge the battery for a little bit longer than a normal charge in order to equalize all cells.

Automatic balancing charge

In the case of the built-in charger, the controller selects the “EQUAL” mode automatically once of ten charges even pushing the “AUTO” button.

Manual balancing charge

Balancing charge is required for the following cases.

- Every two weeks when the lift truck is operated every day.
- Not charged for a couple of days after discharged.
- Over-discharged.

○ Charging procedure

Push the “EQUAL” button as the same way as with a normal charge.
“EQUAL” lamp (orange) will turn on.



If the battery plug is disconnected, the memorize of time of charging is cleared in the controller and the automatic balancing charge function is not activated properly. In this case, the manual balancing charge is recommended.

Start the balancing charge.

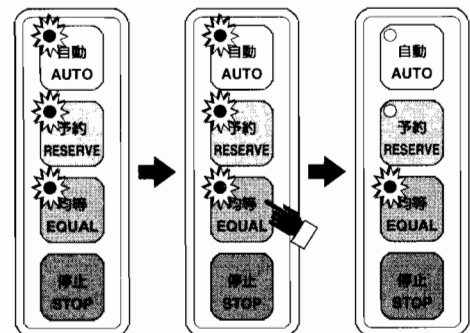

▶ Supplementary charging

When one charge is not enough to finish the daily work, a supplementary charge should be done during a break time.

The procedure of the charge is the same as with a normal charge.



When the ambient temperature is low, the automatic supplementary charge function may be activated.



Push the STOP button first before disconnecting the battery plug when a charge is interrupted.

▶ Charging for long time storage

Carry out the balancing charge before storage.

The periodical charge for every 15 to 30 days is recommended while in storage.

▶ Check the specific gravity

After charging the battery, check the specific gravity.

(Refer the section of "Level of electrolyte and specific gravity" for details.)

How to charge the battery (By stationary charger)

Stationary charger

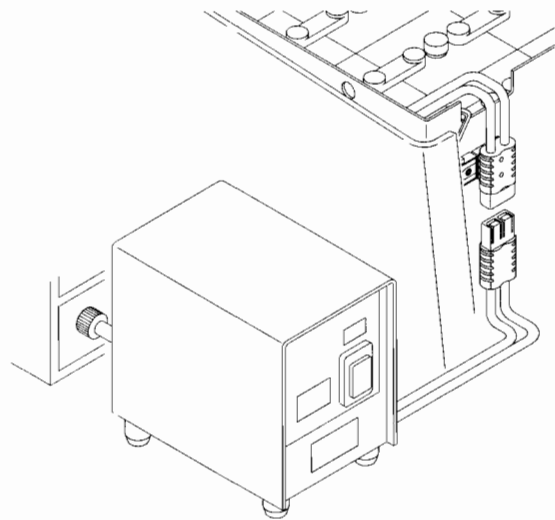

Control panel (Controller)

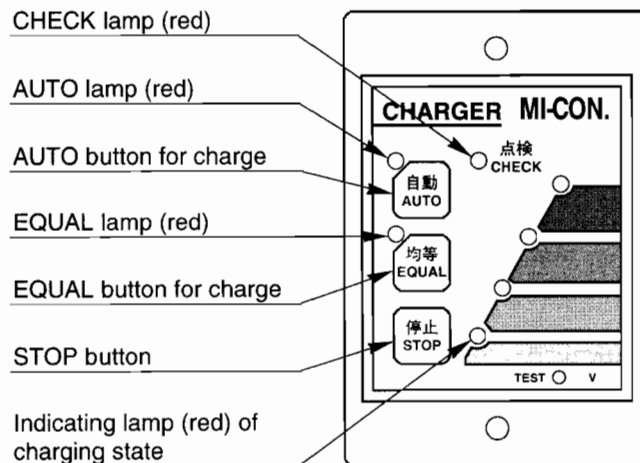

Lamps indicate the state of charging. The four lamps turn on from bottom to top by turns in accordance with the charging state. All four lamps turn on when charged fully.

► Normal (Daily charge)

This charge returns the battery to a fully charged condition after operating the forklift truck.

- ① Move the forklift truck to designated charging area.
- ② Turn off the key switch and remove the key.

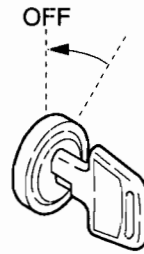

[How to open the battery cover of FB10P-28P.]

Release the bonnet catch and open the battery cover.



Gas spring (assist damper with self locking) is used at the battery cover. Make sure the condition of locking.



Make sure that the locking pin is secured in the hole.

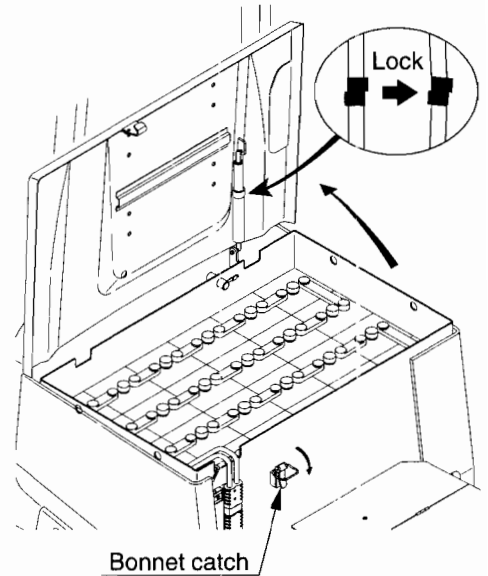

[How to open the battery cover of FB30P.]

Release the bonnet catch and open the battery cover.



Do not release the lock at the top of the battery cover.



Gas spring (assist damper with self locking) is used at the battery cover. Make sure the condition of locking.



Make sure that the locking pin is secured in the hole.

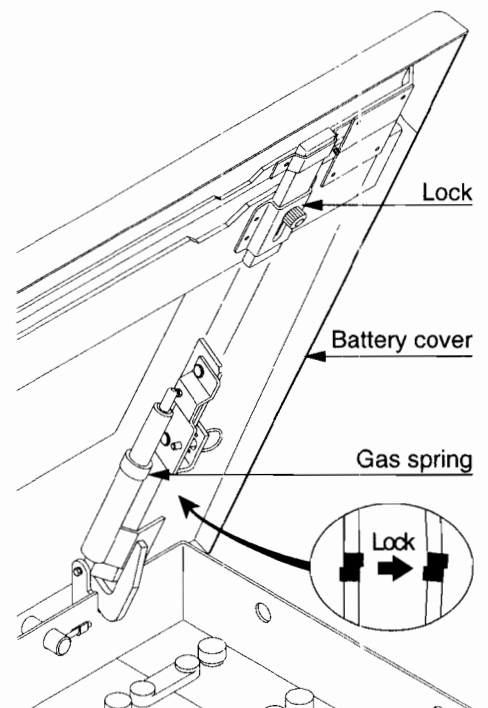

[How to open the battery cover of FB35PJ.]
 Release 2 bonnet catches. And open the battery cover
 ① fully as the gas spring is locked.



The battery cover may hit to the steering wheel when they are opened. Adjust the steering position forward and the seat position backward before opening the battery cover.



Gas spring (assist damper with self locking) is used at the battery cover. Make sure the condition of locking.



Make sure that the locking pin is secured in the hole.

Pull the battery cover ② to open.

③ Disconnect the battery plug.

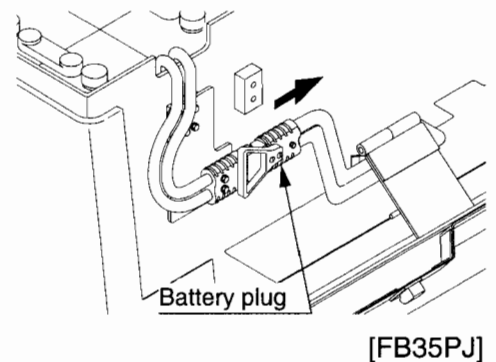
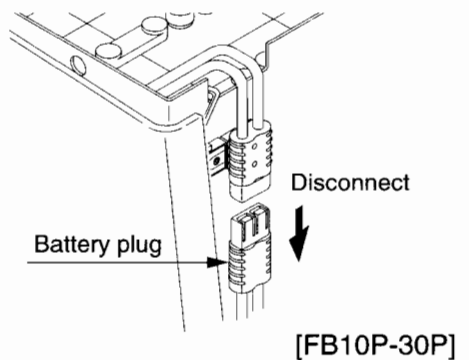
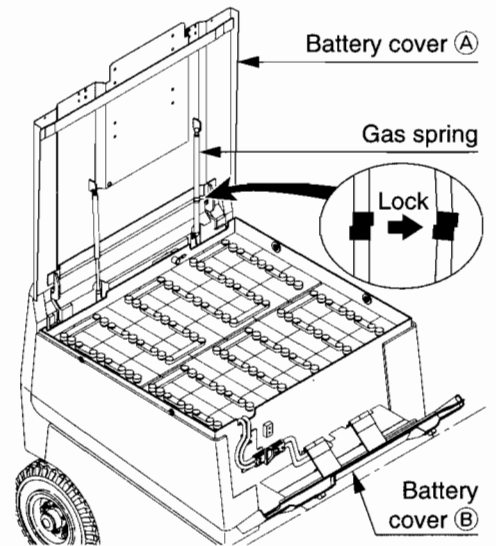
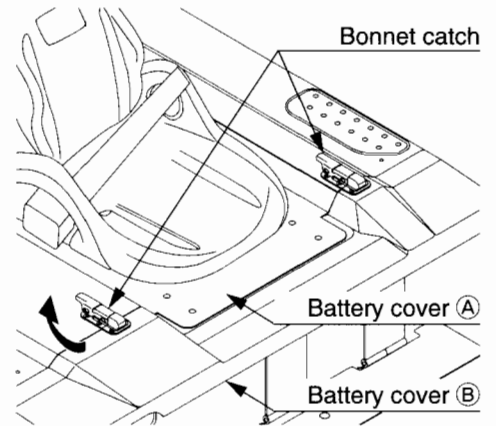

- ④ Connect charge plug from the charger with battery.
- ⑤ Connect the A.C. plug of the charger with wall outlet.

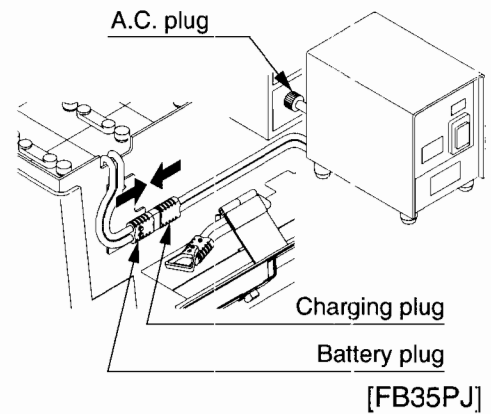
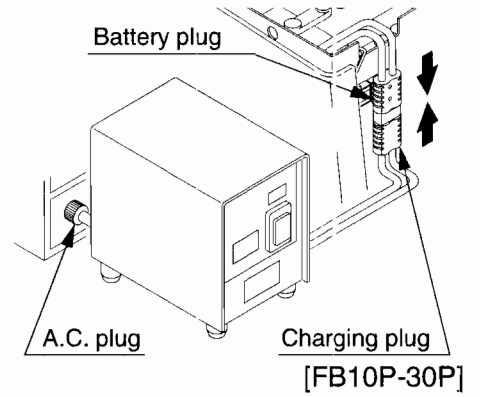

Then both "AUTO" and "EQUAL" lamps turn on.



If "AUTO" and "EQUAL" lamps do not turn on, make sure the charger's cable is connected correctly.

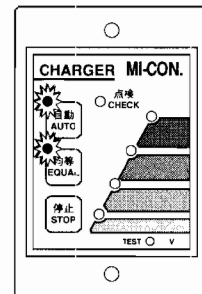

- ⑥ Push the "AUTO" button.
The "AUTO" lamp (red) is turned on, and "EQUAL" lamp is turned off.

Automatic charge is started.

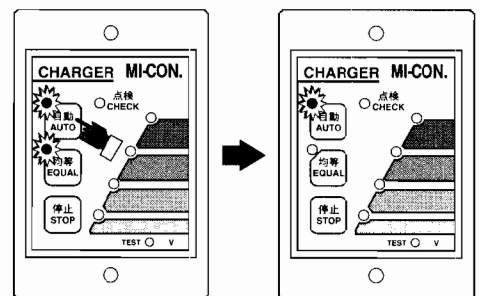

- ⑦ When charge is completed, all four lamps (red) of charging state are turned on.

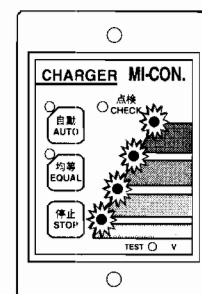

Charge is stopped automatically.

- ⑧ Disconnect the rectangular plug and AC plug.
- ⑨ Push the yellow stopper at the center of the gas spring and close the battery cover.

Closing battery cover

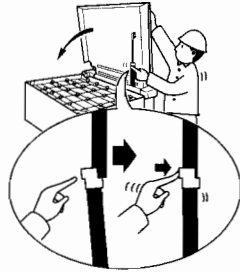

Be careful not to pinch hands or fingers between battery cover and case.

- ⑩ Apply the bonnet catch after closing the battery cover.



- Do not disconnect the rectangular plug, AC plug and battery plug while charging.
- Do not operate any hydraulic valve levers or accelerator pedal while charging.
- Push the "STOP" button when discontinue to charge.



Do not touch any parts of charger and cable by wet hand.

- The charger operates with high voltage. Touch by wet hand may cause electrical shock.

► Balancing charge

Specific gravity of electrolyte in each cell becomes unbalanced after a certain time of charge. In this case, charge the battery for a little bit longer than a normal charge in order to equalize all cells.

Manual balancing charge

Balancing charge is required for the following cases.

- Every two weeks when the forklift truck is operated every day.
- Not charged for a couple of days after discharged.
- Over-discharged.

○ Charging procedure

Push the "EQUAL" button the same way as with a normal charge. "EQUAL" lamp (red) will turn on.



- If the battery plug is disconnected, the memory of time of charging is cleared in the controller and the automatic balancing charge function is not activated properly. In this case, the manual balancing charge is recommended.
- If the forklift truck is not used for a long time after completion of charge, the supplement charge function is activated automatically. Then, the "AUTO" lamp is flashed.

Start the balancing charge.

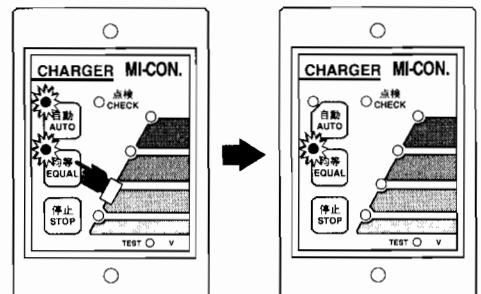

► Supplementary charging

When one charge is not enough to finish the daily work, a supplementary charge should be done during a break time.

The procedure of the charge is the same as with a normal charge.



When the ambient temperature is low, the automatic supplementary charge function may be activated.

In this case, the "AUTO" lamp will flash while charging.



Push the STOP button first before disconnecting the battery plug when a charge is interrupted.

► Charging for long time storage

Carry out the balancing charge before storage.

The periodical charge for every 15 to 30 days is recommended while in storage.

► Check the specific gravity

After charging the battery, check the specific gravity.

(Refer the section of "Level of electrolyte and specific gravity" for details.)

■ Level of electrolyte and specific gravity

▶ Electrolyte level

If the battery is used when the electrolyte level is low, the battery will become overheated causing it to have a shorter life.

- When the battery level sensor which is mounted on the side of the battery case shows the red flashing, the electrolyte level is too low.
(Level sensor is equipped on the Japanese battery only.)

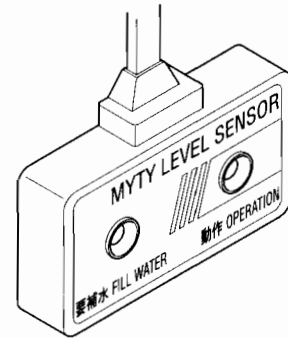

- When the *REPLENISH REFINED WATER FOR BATTERY* message is shown on the display, the electrolyte level is too low.
(Refer section : MONITOR DISPLAY)
(This function is option with GS battery only.)

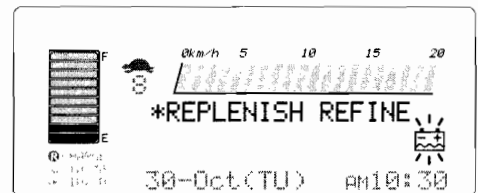

▶ Check of electrolyte level

Electrolyte level can be checked by the float which is equipped in the vent cap.

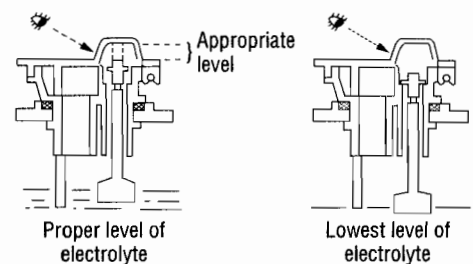

(N.B. This is the case of GS brand battery)

► Replenishment of water

To maintain the specific level of electrolyte, replenish with refined water.

(You do not need to replenish the sulfuric acid. Use refined water only.)

Wear safety goggles, rubber gloves and boots for your protection.

- ① Open the vent caps of all battery cells.
- ② Replenish water into each cell.

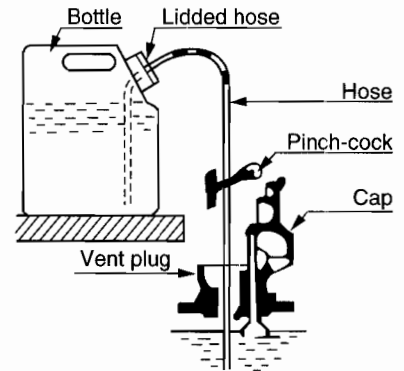

- ③ Stop replenishing when the red float is raised and the white line appears.

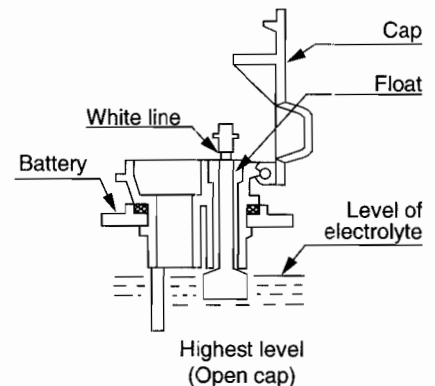

(N.B. This is the case of GS brand Battery)

- ④ After replenishing to all cells, close all vent caps completely.
- ⑤ Clean the top of cells by wet cloth.



- Do not replenish water over the maximum level.
- Overfilling will cause the electrolyte to overflow while charging resulting in damage to the forklift truck.



► Reading of specific gravity

The specific gravity of electrolyte is changed by temperature.

Measure the temperature of electrolyte by a thermometer and the gravity of electrolyte by a hydrometer.

Convert the actual gravity to the specific one at 20°C by the thermal conversion table.

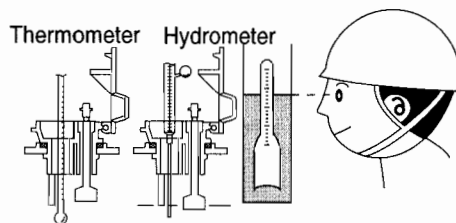

Specific gravity at full charged	1.280 (at 20°C)
Specific gravity at discharged	1.180 (at 20°C)



When the specific gravity is below 1.18 at 20°C, should be done the balancing charge.

SPECIFIC GRAVITY OF ELECTROLYTE AND THERMAL CONVERSION TABLE



How to convert the specific gravity:
For example, if the hydrometer reading is 1.25 at 5°C, the specific gravity at 20°C is 1.24.

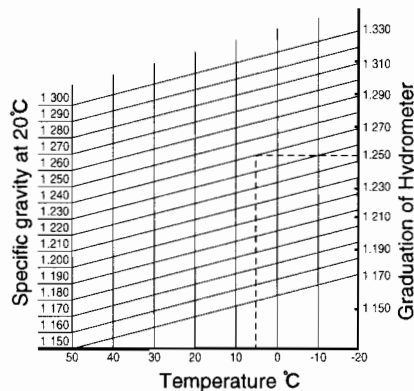

■ Exchanging battery



- When an exchange of a battery is required, the discharged battery should be charged as soon as possible.
- Exchange the battery on the flat floor with following procedure.

The wrong battery size can cause a reduced work time and poor stability. Poor stability could cause the lift truck to overturn. Observe the following range of the battery weight.

	FB10P FB14P	FB15P FB18P	FB20P	FB25P FB28P	FB30P FB35PJ
Minimum	560	640	710	815	1095
Maximum	800	800	1110	1110	1320

(kg)

○ Procedure to exchange

- ① Turn off the key switch and disconnect the battery plug.
- ② How to open the battery cover.

(In case of FB10P through 28P)

Release the bonnet catch and open the battery cover.

(In case of FB30P)

- 1) Release the bonnet catch and open the battery cover until the left gas spring is locked.
- 2) Release both right and left stoppers under the battery cover, and flap the top of the cover down. The stopper can be released by pulling and sliding down the knob.
- 3) Open the battery cover again until the locking pin catches the hole.



Make sure that the locking pin is secured in the hole.



Gas spring (assist damper with self locking) is used at the battery cover.
Make sure the condition of locking.

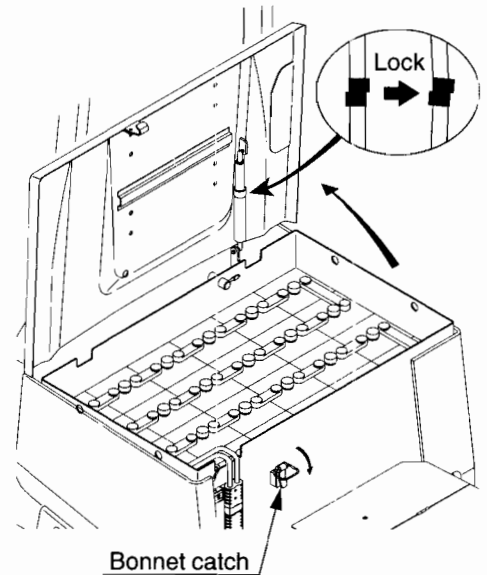
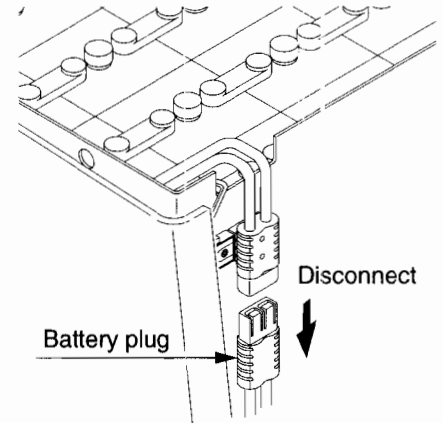

How to open the battery cover of FB30P.

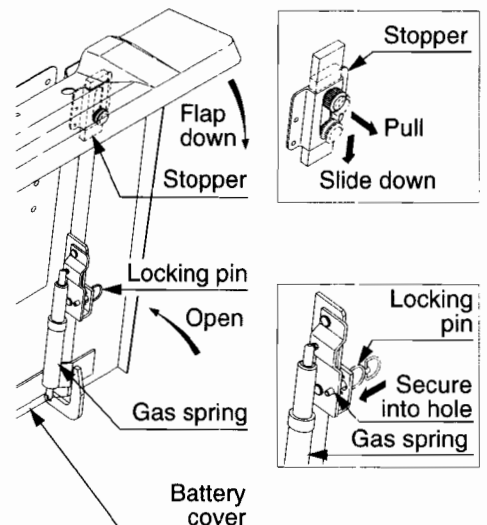

(In case of FB35PJ)

1) Release 2 bonnet catches. And open the battery cover ① fully as the gas spring is locked.



The battery cover may hit to the steering wheel when they are opened. Adjust the steering position forward and the seat position backward before opening the battery cover.



Gas spring (assist damper with self locking) is used at the battery cover. Make sure the condition of locking.



Make sure that the locking pin is secured in the hole.

2) Pull the battery cover ② to open.

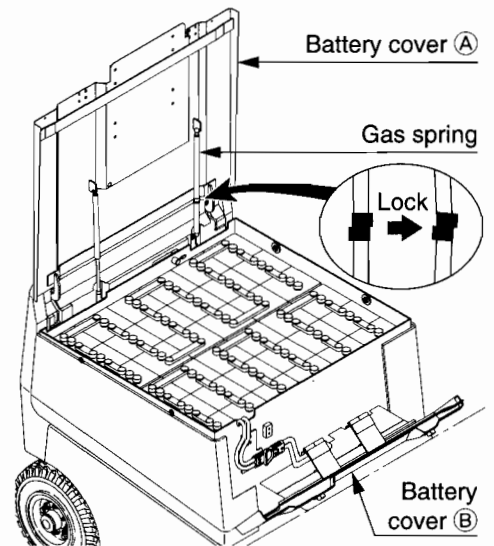
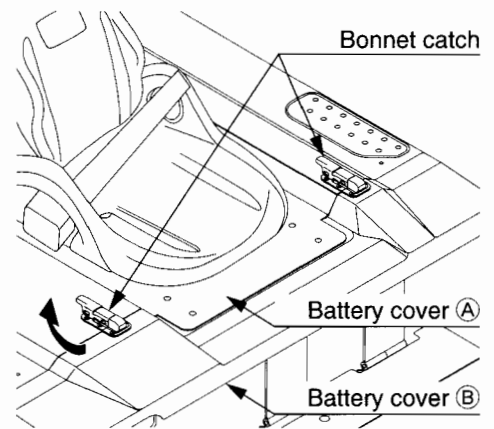

4

BATTERY AND CHARGER

- ③ Tilt the steering wheel up completely.
- ④ Remove the battery lock pin and side covers.
- ⑤ Exchange the battery by using slings and hooke.



- Be careful not to pinch hands or fingers when removing and installing side covers.
- When exchanging the battery by another lift truck, use proper slings and hooks.
- When lifting up the battery, be careful not to damage the chassis or equipment.

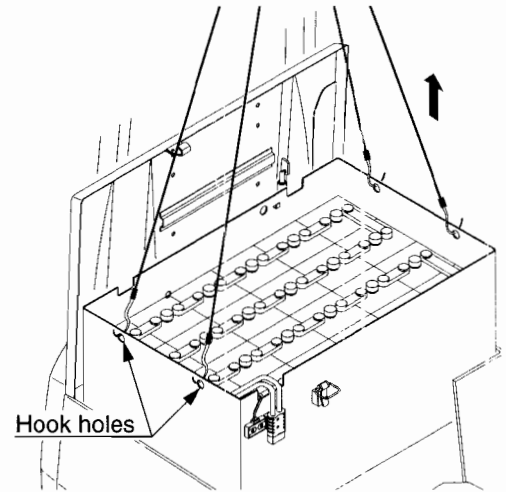

- ⑥ After exchanging the battery, insert the battery lock pin, install side covers and close the battery cover.

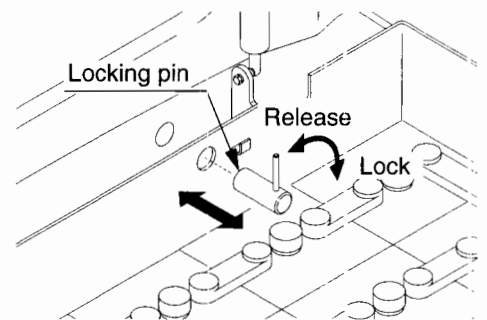

- ⑦ How to close the battery cover of FB30P.

(For FB30P only)

- 1) Pull the locking pin and close the battery cover until the left gas spring is locked.
- 2) Flap the top of the battery cover up, and fix it with both right and left stoppers. The stopper can be locked by pulling and sliding up the knob.

How to close the battery cover of FB30P.

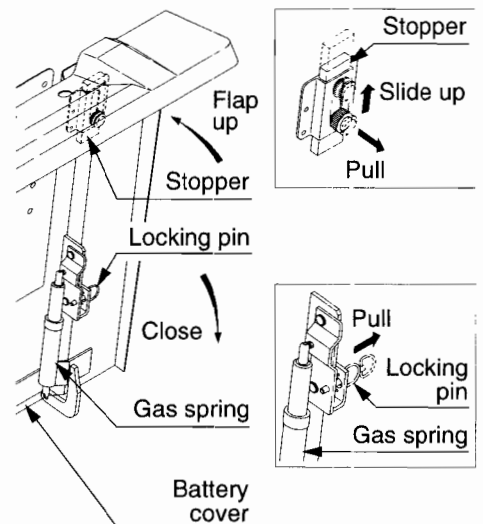

- ⑧ Push the yellow stopper at the center of the gas spring and close the battery cover.



- Be careful not to pinch hands or fingers between battery cover and case.

- ⑨ Apply the bonnet catch after closing the battery cover.

Closing battery cover

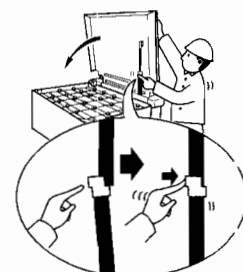

5

INSPECTION PRIOR TO OPERATION

A daily pre-operation inspection is the key to safety and keeping the forklift truck in good condition. At the beginning of each shift, check your forklift truck to make sure it is in safe operating condition. If faults are found, contact NICHYU's qualified facility.



- Do not operate the forklift truck until finishing repairs and inspections.
- Inspecting trucks should be made on a flat floor.
- Be sure to turn off the key switch and disconnect the battery plug while checking the electrical system except while turning on the lamps and checking operation.



5

Check point and contents

	No.	Check points	Contents
Safety monitor	1	Function	When key switch is turned on, "MONITORING OK" is displayed
Lamp & Horn	2	Head lamps, Turn signal lamps, Horn	Turn on and off, Sound
Braking system	3	Brake fluid	Quantity and fouling (The quantity of the brake fluid is checked by the safety monitor. If "MONITORING OK" is displayed on the screen when the key switch is turned on, the quantity is normal.)
	4	Parking brake	Pulling force of lever and braking force
	5	Brake pedal	Stroke of foot brake pedal and braking force
Steering system	6	Play of steering wheel	Play and looseness, Operating condition
	7	Power steering operation	Operating of all parts
Hydraulic system & Mast	8	Function	Function, Any cracks, Lubrication
	9	Hydraulic oil	Appropriate quantity
	10	Lift chains	Equal tension of both right and left chains
	11	Oil piping	Oil leakage
Wheel	12	Tyres	Abnormal wearing and / or damage
	13	Hub nuts	Securely tighten
Battery	14	Charging	Check battery capacity indicator and specific gravity, Plug is securely connected
Others	15	Overhead guard, Load backrest	Securely tighten fitting bolts and nuts
	16	Laser pointer (Option)	Focus of beam
	17	Others than above	Any abnormality

■ Inspection procedure

① Check functions of safety monitor

[MONITORING OK] is displayed for a few seconds after turning the key switch on at normal condition.

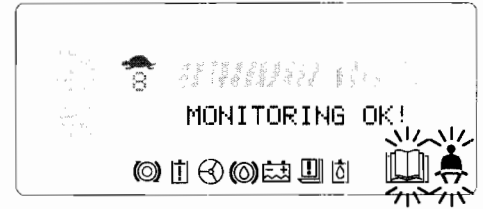

② Check head lamps, tail lamps, turn signal lamps and horn

Check operation of lamps.

Check sound of horn.

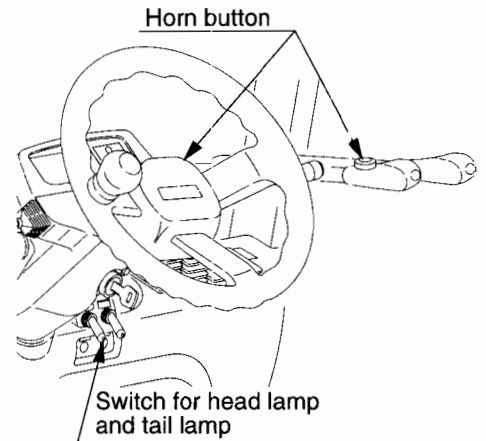

Switch for turn signal lamp

Right

Left

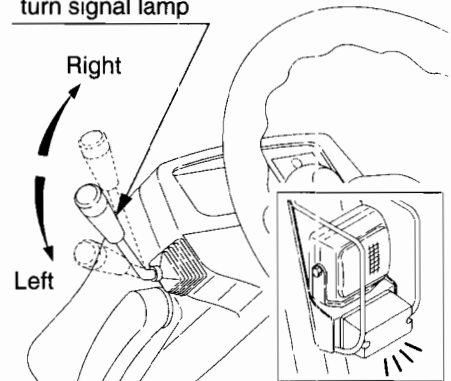

③ Check brake fluid

If "REFILL BRAKE OIL" message is appeared on the display, remove the cap from the brake fluid reservoir and check the level and condition of the fluid.



Do not spill the brake fluid on any painted surface. Any spillage will cause the painted surface to become damaged.

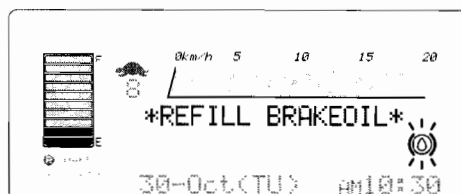
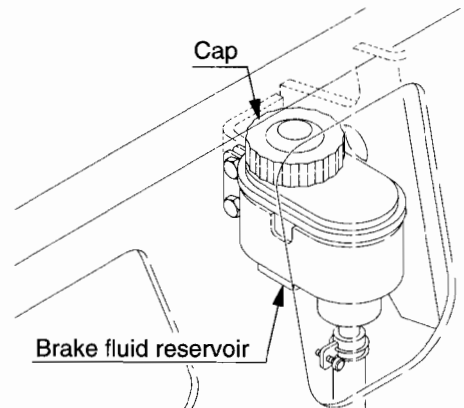

④ Check parking brake lever

Pulling the parking brake lever and check :

- Suitable pulling force (170-220N), (17-22kgf)
- Enough braking force
- No damaged parts

Adjust the pulling force by the adjust screw at the bottom of the lever.

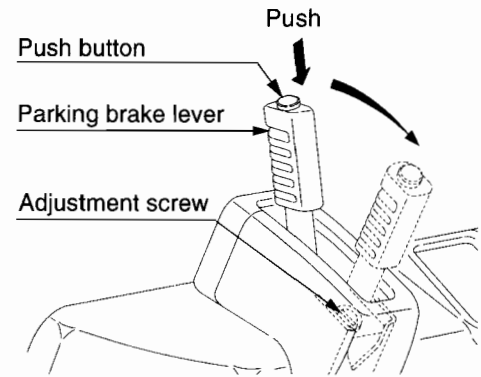
**⑤ Check foot brake pedal**

Check performance of brake and make sure the stroke of the foot brake pedal.

Proper braking distance without a load is about 2.5m.

Adjust if the braking distance is more than above specs.

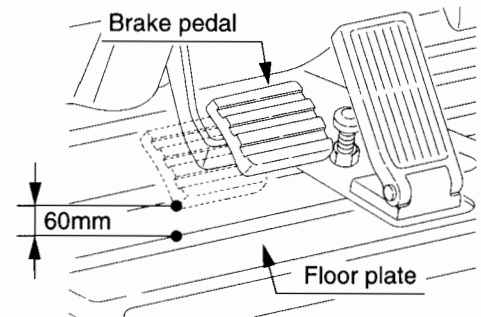
**⑥ Check play of steering wheel**

Turn the steering wheel to the right and left, and check the free play (50-100mm). The steering wheel moves up and down approximately 2mm. This is normal.

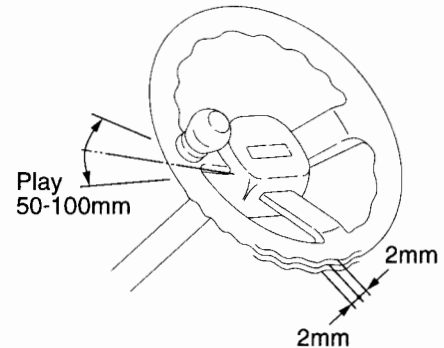
**⑦ Check power steering function**

Turn the steering wheel to the right and left to check the steering operation.

⑧ Check the hydraulic functions

Check if lifting and tilting operations are smooth.

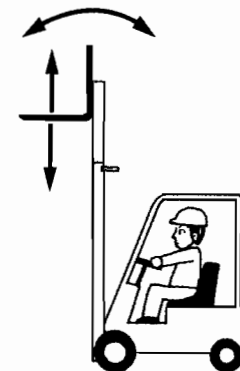

⑨ Check hydraulic oil

Check oil level by using the level gauge when the forks are lowered on the floor.

Appropriate oil level is within the range of H and L.

Applicable model	H	L
FB10P/14P/15P/18P	22 ℓ	19.5 ℓ
FB20P/25P/28P	26 ℓ	23 ℓ
FB30P	29 ℓ	26 ℓ
FB35PJ	28 ℓ	26 ℓ

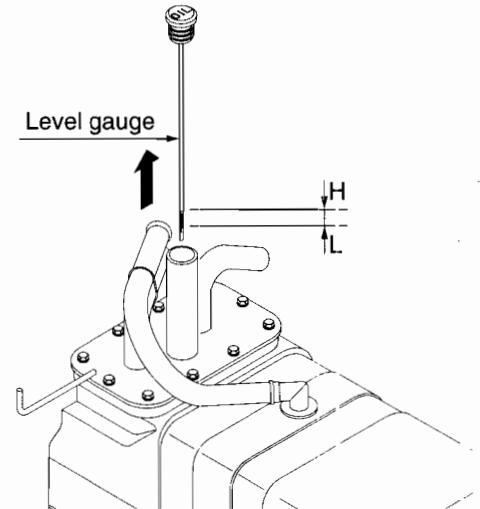

[FB10P-18P]

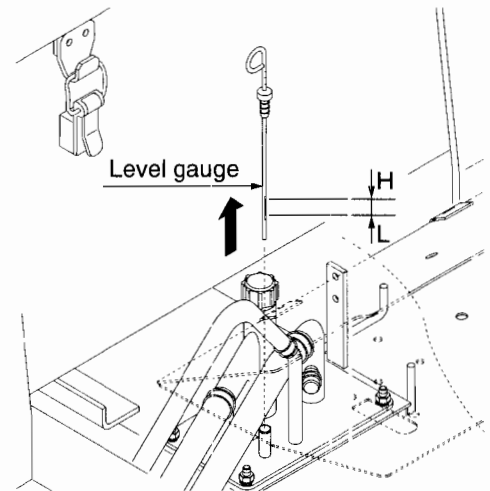

[FB20P-30P, FB35PJ]

⑩ Check lift chains

Raise the forks 200-300mm above the floor and check if the tension is the same for both right and left chains. The mast carriage should be level. If the carriage leans to the right or left, adjust the chain anchor bolts.



After proper adjustment, tighten up the lock nuts securely.

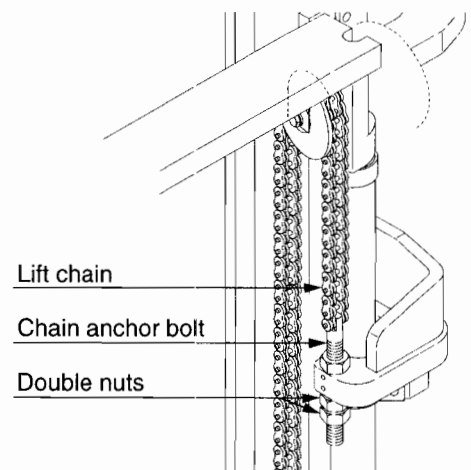

⑪ Check oil piping

Check for any oil leakage from the lift cylinders, tilt cylinders and oil piping.

⑫ Check tyres

Measure the air pressure by using the air pressure gauge.

Standard air pressure

KPa (kgf/cm²)

Models Tyres	FB10P FB14P	FB15P FB18P	FB20P FB25P FB28P	FB30P	FB35PJ
Front	850 (8.50)	900 (9.00)	900 (9.00)	800 (8.00)	800 (8.00)
Rear	850 (8.50)	850 (8.50)	900 (9.00)	700 (7.00)	900 (9.00)

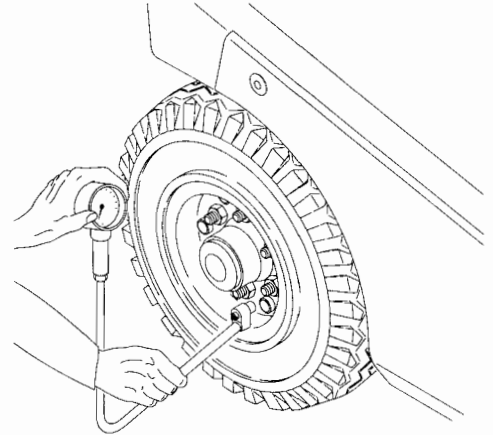

After checking air pressure, check that no air is leaking from the valve.

⑬ Check hub nuts

Check if the hub nuts are secured by tightening them with a torque wrench.

Specific torque

N·m {kgf·m}

Models	Front tyres	Rear tyres
FB10P / FB14P	89-108 {9-11}	89-108 {9-11}
FB15P / FB18P	216-264 {22-27}	
FB20P - FB30P FB35PJ	315-385 {32-39}	

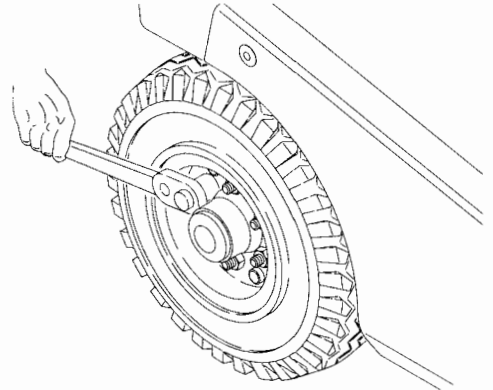

⑭ Check charging

Measure the specific gravity of battery. When it shows 1.260-1.280 at 20°C conversion, the battery is fully charged.

⑮ Check overhead guard and load backrest

Check if all fitting bolts and nuts are correctly secured and torqued.

⑯ Check beam of laser pointer (Option)

If optional laser pointer is equipped, irradiate the beam and check its focus.

Laser beam
(Dot type)

Laser beam
(Line type)

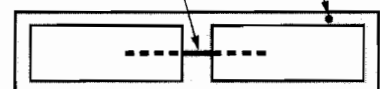

⑰ Others

Check for any other abnormalities.

6

INSPECTION OF AFTER OPERATION

■ Inspection after working

At the end of each shift, clean the forklift truck and inspect the following items.

- Any damage or oil leakage.
- Apply grease if required.
Refer to [Lubrication points and recommended oil]
- Raise the lift carriage to the maximum lifting height several times if your normal operation did not require to do so. (The hydraulic oil is supplied to the full stroke of the cylinder by lifting to the maximum height. It helps to prevent rust from forming inside the cylinders.)
- Check any abnormal parts which are found any defects while operation.



- **A small fault can cause a serious accident.**
- **Do not operate the forklift truck until finishing repairs and inspections.**



If the forklift truck will be stored for a long time, the following maintenance should be done.

- 1. The lift truck should be stored where is no rain or snow, the temperature between -10°C and 40°C , and no open flames.**
- 2. The balancing charge should be done every 15 to 20 days while storing.**
- 3. Raise the lift carriage to the maximum lifting height several times once a month to protect the lift cylinder from corrosion.**

7

PERIODIC SERVICING



Periodic inspections and maintenance are necessary to keep your NICHYU forklift truck running safely and smoothly. Hours shown in the maintenance schedule are based on eight hours operation per day and 200-hour operation per month. Make your own maintenance schedule using this formula for your operation requirements.



All servicing and repairs shall be made by authorized personnel.

- Contact NICHYU's qualified facility for adjustments and/or repairs.

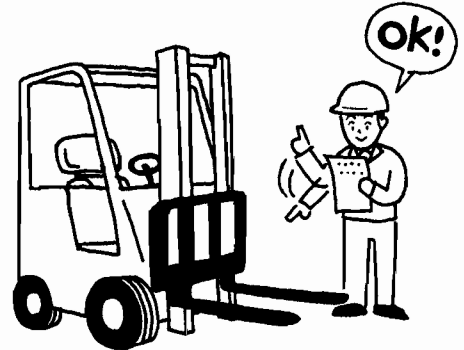

■ Precautions of maintenance



Use NICHYU genuine parts for replacement. If non-genuine parts are used and a problem occurs, NICHYU will not offer any guarantees.



Use NICHYU recommended oil. Refer to [Recommended oil].

► Maintenance place



- Servicing facility should provide adequate equipment and safety guards.
- Servicing place should be on a flat floor.
- Be sure there is adequate ventilation in the service area.
- Fire extinguishers shall be provided at the servicing facility.

6

7

► Precautions of maintenance



- Smoking shall be prohibited.
- Wear safeguard (helmet, shoes, glasses, gloves and boots) and suitable clothes.
- Wipe off spilt oil at once.
- When lubricating, remove grease and dust off nipples and fittings with a brush or a cloth before lubrication.
- Turn off the key switch and disconnect the battery plug except when required for trouble shooting.
- When servicing a forklift truck, lower forks to the floor.
- Clean the electrical components with compressed air.

► Precautions during servicing



- Do not put your feet under forks and be careful not to stumble over forks.
- When forks are lifted up, put blocks under the inner mast to prevent the mast and forks from falling.
- Be careful not to pinch your hands when opening and closing the covers and clamps.
- When working as a group, be sure everyone works safely with each other.
- Use only suitable tools.
- The hydraulic circuit may have a high pressure condition. Release the inside pressure before performing any service or repairs.
- Do not climb on the mast.



Never put any part of your body into mast structure or between mast and forklift truck.

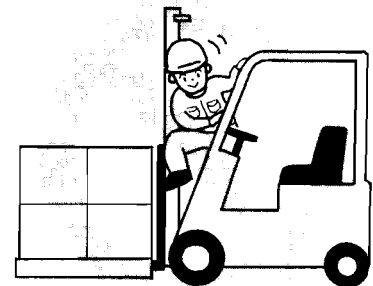

► Maintenance of the lift cylinder



The lift cylinder has the special construction for the shock absorbing function. Please contact to your local NICHYU dealer for disassembling and assembling.

► Inspection and exchange of tyre



- Leave a dismounting and mounting tyres to NICHYU's qualified service facility.
- Handling a high pressure air shall be made by authorized personnel.
- When use a compressed air, wear goggle.
- When dismounting the tyre, do not loosen bolts and nuts of joint rim. As inside tyre is high pressure, there is a danger of breaking bolts, nuts and rim.



► Jacking up



Do not go under the forklift truck while it is being jacked up. Failure to observe this warning can cause serious injury or death if the forklift truck falls on you.



- Before jacking up the forklift truck, make sure no one is around and no load is on the forklift truck.
- Before jacking up, place wheel chocks at tyres.
- After jacking up, use blocking or proper stands to prevent the forklift truck from falling.

► Hoisting the truck



- Lift the forklift truck by trained persons only.
- Place slings and hooks to the designated positions.
- Use slings and hooks which have sufficient strength.

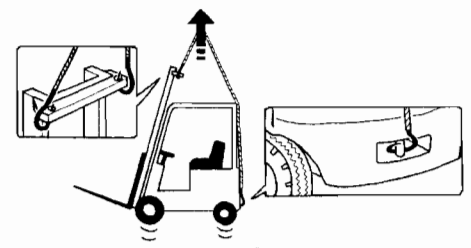

■ Weekly (50-hour) servicing

Inspect the following items in addition to the inspection prior to operation.

Check points	Contents
Electrolyte level	Check the electrolyte level. When the level is low, replenish with refined water.
Specific gravity of electrolyte	Measure the specific gravity and temperature of electrolyte of all cells.
Cleaning of battery	Clean the top surface and vent cap of each cell.



Be sure to disconnect the battery plug when inspecting the electrical system.

► Check the level of electrolyte

Refer to [Level of electrolyte and specific gravity].



- After completing the replenishment, securely close the vent caps.
- Do not replenish the water over the maximum level.

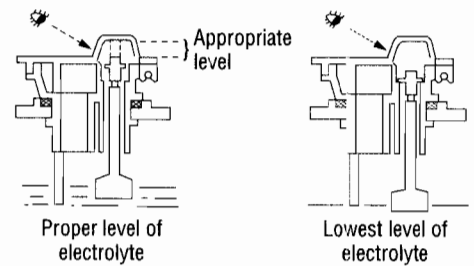

(N.B. This is the case of GS brand battery)

► Check for specific gravity of electrolyte

Measure the quantity and specific gravity of all cells.

Normal : It is normal when all cells specific gravity are the same.

Abnormal : It is abnormal if the difference of the specific gravity is more than 0.05 from other cells.

Refer to [Battery electrolyte and specific gravity] how to inspect the specific gravity of battery.

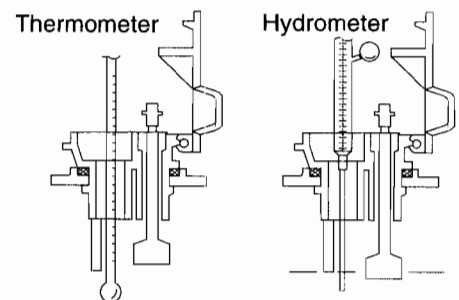

► Cleaning of battery

Keep the battery clean by wiping off with a damp cloth.



- The battery should be cleaned before charging.
- Wear rubber gloves and boots to prevent an electrical shock.
- Do not clean the battery plug with water.

The inside of vent caps will be stained and making of the float difficult to see. Clean the caps by the following procedures.



This is the case of Japanese battery.

- ① Remove the vent caps by turning counterclockwise.
- ② Wash the inside of vent caps with a neutral detergent. If they are severely stained, brush them.
- ③ Install the vent caps by turning clockwise.



Make sure all vent caps are completely closed.

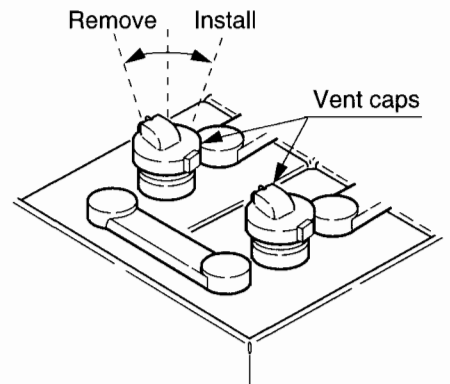

Monthly (200-hour) servicing

Perform the following service in addition to the weekly (50-hour) maintenance schedule. If an adjustment or replacement parts is required, contact NICHYU's qualified facility.

System	No.	Check points	Contents
Truck	1	General	Distortion, crack and abnormal noise
	2	Seat belt	Crack and damage
	3	Horn	Sound
	4	Accessories (Head lamp, Turn signal lamp)	Function
Battery, Charger & Electric System	5	Battery electrolyte	Quantity, specific gravity and clean
	6	Terminal plug	Damage and clean
	7	Plug for charger (Opt.)	Looseness and damage
	8	Magnet switch for charger (Opt.)	Function and contacts
	9	Pilot lamp for charger (Opt.)	Turning on and off
	10	Key switch	Function
	11	Contactors	Contacts and function
	12	Microswitch	Function
	13	Controller	Function
	14	P.S. motor (Brush, commutator)	Wearing and spring force
	15	Control unit	Current limitation and function
	16	Fuses	Looseness and capacity
	17	Wiring, Terminal	Damage and looseness
Drive, Steering, Mast, Hydraulic & Braking System	18	Steering wheel	Play and movement
	19	Steering linkage	Lubrication
	20	Gear case	Oil quantity, leakage and abnormal noise
	21	Fitting nuts for tyres	Looseness
	22	Tyres	Damage and wearing
	23	Lift chain	Lubricant and tension
	24	Cylinder rod guide pin	Looseness and damage
	25	Lift bracket	Adjustment, lubricant, crack and distortion
	26	Forks	Crack and transformation
	27	Lift rollers	Adjustment and lubricant
	28	Mast rollers	Adjustment and lubricant
	29	Outer mast, Inner mast	Jolt
	30	Lift cylinders	Oil leakage
	31	Tilt cylinders	Oil leakage
	32	Control valve	Function and oil leakage
	33	Hydraulic tank	Oil quantity and oil leakage
	34	H.P. hoses	Oil leakage and transformation
	35	Overhead guard, Load backrest	Damage, crack and transformation
	36	Brake linkage	Lubricant and movement
	37	Parking brake lever	Adjustment
	38	Bolts, nuts	Function
	39	Power steering	Function

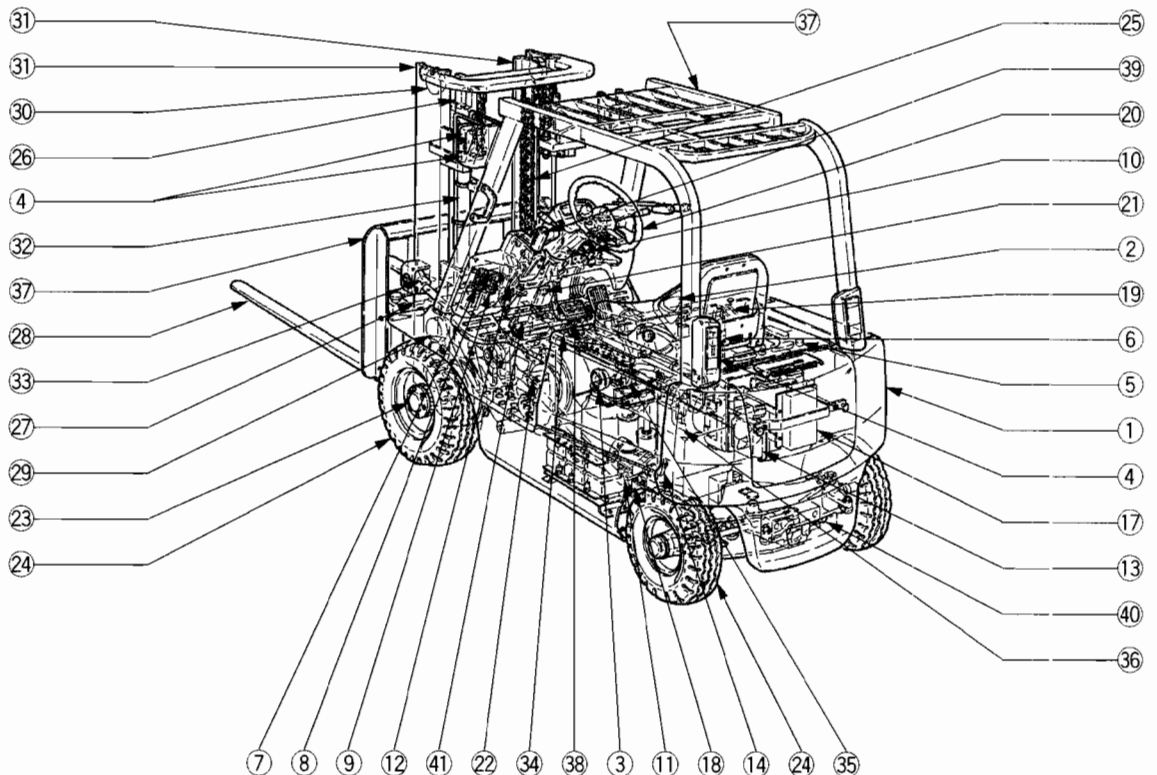

Illustration shows FB15P.

■ Lubrication points and recommended oil

► Lubrication points

- | | | |
|----------------------|---------------------|--------------------|
| ○ : Lubrication | CG : Chassis grease | BO : Brake oil |
| ⊙ : Replace | GO : Gear oil | RG : Rubber grease |
| □ : Check and adjust | HO : Hydraulic oil | W : Refined water |

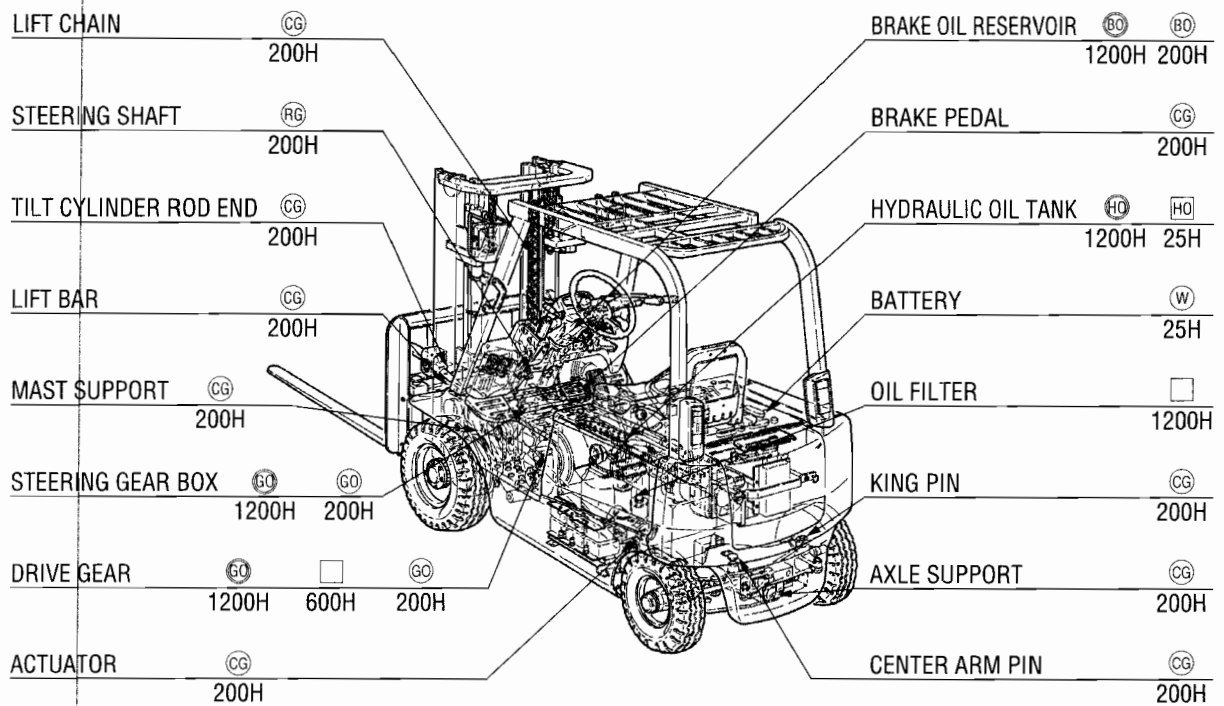

Illustration shows FB15P.

► Recommended oil

Manufacturer	Shell	ESSO	Mobile
Gear oil	Splyuxe EP 80	ESSO Gear Oil GP SAE 80	Mobilube GX-80
Grease	Alvania Grease 2	ESSO Beacon 2	Mobiluxe 2

Use NICHYU genuine parts "NICHYU FORK OIL B" for hydraulic oil.

■ Every three-month (600-hour) servicing

Perform the following service in addition to the monthly (200-hour) maintenance schedule.

If an adjustment or replacement parts is required, contact NICHYU's qualified facility.

Check points	Contents
Contactors	When roughness is excessively, replace it.
Power steering motor	Wearing of the carbon brushes.

■ Semiannually (1200-hour) servicing

Perform the following service in addition to the (600-hour) maintenance schedule.

If an adjustment or replacement parts is required, contact NICHYU's qualified facility.

Check points	Contents
Contactors	When roughness of the contact is excessively replace it.
Power steering motor	Wearing of the carbon brushes.
Front axle	Change of gear oil
Hydraulic oil	Change of hydraulic oil
Oil filter	Cleaning the oil filter
Brake fluid	Check condition, and change fluid if dirty.

● Inspection of motor brushes

Raise up the whirl spring and then pull out the carbon brush to check the length.

If the brush is worn more than the wearing limit, replace all brushes of the motor.

Wearing limit carbon brushes (mm)

	H	Wearing limit	Qty
Power steering	25	15	2

(Wearing limit is marked on carbon brushes.)

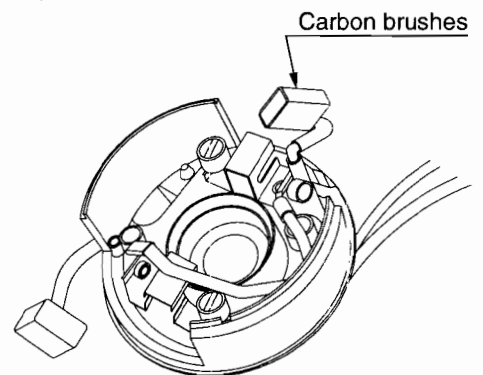
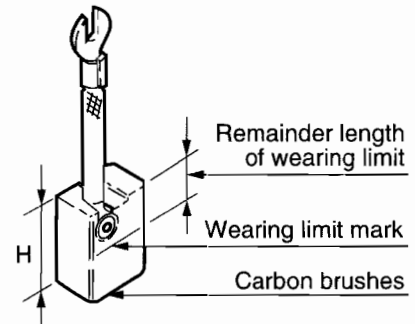

■ Replacing parts and trouble shooting

▶ Replacing fuses



Be sure to disconnect the battery plug.

- ① Fuse 160A (For transformer)
- ② Fuse 40A (For EPS)
- ③ Fuse 325A (For hydraulic / travel)
- ④ Tube fuse 10A (For control circuit)
- ⑤ Tube fuse 10A (For accessory circuit)

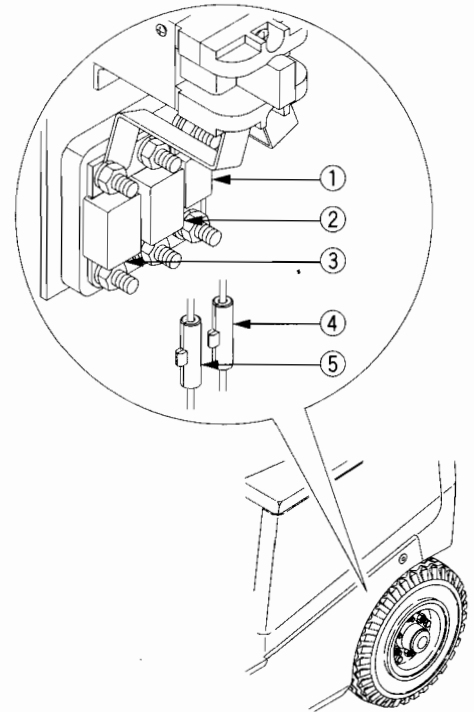

Replacing procedure	
Fuse	Loosen the mounting nuts and removing the fuses.
Tube fuse	Loosen a cap and removing the fuse.
Insufficient tightening of the mounting nuts may cause of poor contact and it can cause overheating or fire. Tighten the nuts securely.	



Be sure to use the fuses with the same voltage and amperage rating.

▶ Replacing fuses of charger for three phases power supply

These fuses are installed if the built-in charger is equipped.



Be sure to disconnect the A.C. plug.

Replacing procedure	
Loosen the mounting screws, and replace fuses.	
Insufficient tightening of the screws may cause of poor contact and can cause overheating or fire. Tighten screws securely.	

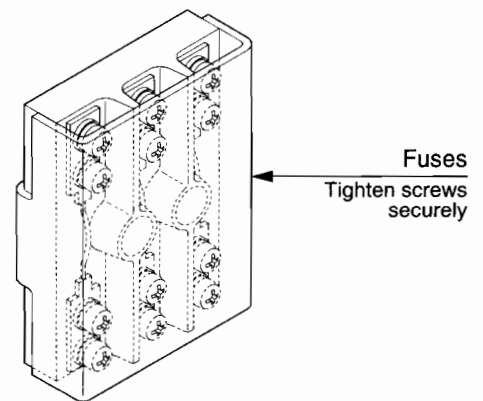

Be sure to use the fuses with the same voltage and amperage rating.

Models	Fuse rating
	200V/220V
FB10P/14P	15A
FB15P/18P/20P	20A
FB25P/28P/30P, FB35PJ	30A

► Replacing bulb

Be sure to turn off the key switch and disconnect the battery plug.

Replacing

Remove a glass of lamp.
Release a bulb by pushing and turning lightly.

Bulb for	Rating
Head lamps	56V (40W)
Back up lamps	56V (10W)
Turn signal lamps	56V (25W)
Tail & Stop lamps	60V (10W / 25W)



Be sure use bulbs with the same voltage and watts rating.

8

QUICK FAULT FINDING



- When checking, be sure to turn off the key switch and disconnect the battery plug.
- When a fault cannot be corrected, contact NICHYU's qualified facility.

To find the following faults proceed as check points.

Troubles	Check points	Solutions
Lift truck does not run.	Fuse for the auxiliary control circuit would be blown out.	If the fuse is blown, replace with new fuse with prescribed amps.
	Fuse for the traveling circuit.	If the fuse is blown, replace with new fuse with prescribed amps.
	Brake pedal microswitch	If no clicking sound occurs when depressing the brake pedal fully, contact your local NICHYU dealer.
	Directional lever microswitch	If no clicking sound occurs even when moving the lever forward or reverse, contact your local NICHYU dealer.
	Battery plug connection.	If the battery plug is loose, securely connect it.
Not charging.	Fuse for A.C. electric source.	If the fuse is blown, replace with new fuse with prescribed amps.
	Charging plug, A.C. plug and battery plug.	If these plugs are loose, securely connect them.
	Fuse for A.C. or D.C. of the charger (In case of built-in charger, fuse for traction motor).	If the fuse is blown, replace with new fuse with prescribed amps.
Lamps do not turn on.	Control and accessory fuse. Lead wires. Bulbs.	If fuses or bulbs are burnt, replace them.

When a fault cannot be corrected, contact NICHYU's qualified facility.

9

PERIODICAL REPLACING PARTS

Periodical inspection and maintenance are very important to keep your forklift truck in good condition.

The parts in the table are also very important for safe operation.

NICHIYU recommends that you replace these parts every period as listed in the Periodical replacement parts chart even if their appearances are good.

The periodical replacement of parts is not covered by warranty.

	Periodical replacement parts	Period
1	Cup and dust seal of brake master cylinder and wheel cylinder	1 years
2	Brake hoses or tubes	2 years
3	Stop switch	2 years
4	H.P. Hose	2 years
5	Lift chains	3 years

STABILITY OF FORKLIFT TRUCK

As shown in the following illustration, the counter balanced lift truck is balanced on its front wheel with the maximum rated capacity load on the forks.

Therefore, careful attention should be paid to the load center.

If the load weight and/or gravity exceed the rated capacity or load center, the rear wheels are lifted and the lift truck tips over.

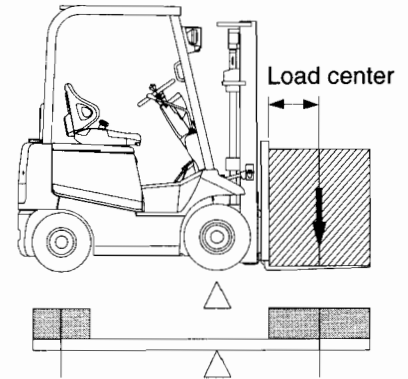

(Illustration shows FB15P)

Load center and load chart

The distance from the vertical front side of the forks to the center of the load is called the load center.

The LOAD CHART shows the relation of the load center and capacity.

Observe the LOAD CHART which are installed on each forklift truck.

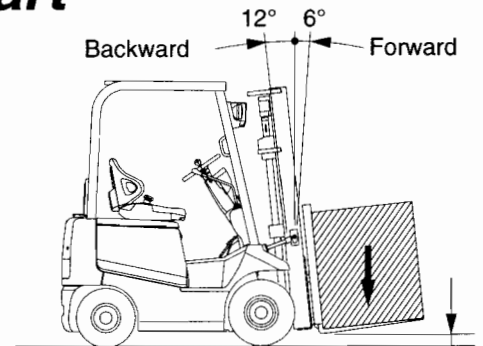

150mm-200mm
(Illustration shows FB15P)



- Lift the forks 150mm to 200mm above the Floor, and tilt the forks up fully while traveling.
- Do not lift or tilt down while traveling.
- This can cause the forklift truck to tip over.



- (1) Insert the fork to the root completely when handling a load.
- (2) If the load is handled by only front part of the fork, a large stress may be applied to the mast and forks. It may cause some damages on the truck.
- (3) Do not handle off-centre load to prevent from damage it by slipping as well as the truck.
- (4) Operate the hydraulic levers carefully when handling a load.
- (5) Do not operate the truck roughly when raising a load at high position. Otherwise, big shock may be applied to the truck which can create turnover.

LOAD CHART

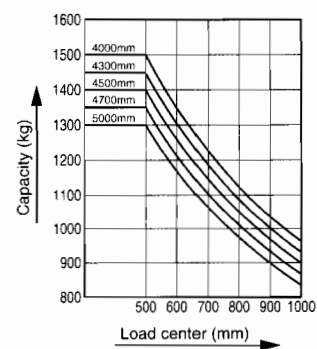

■ *Stability of the forklift truck*

The stability of the forklift truck is prescribed by safety regulation in each country.

The safety of the forklift truck is guaranteed under restricted conditions in those regulations.

So, the safety of the forklift truck is NOT guaranteed for all operating conditions.

The condition is as follows.

- The operating surface must be flat and hard.
- When travelling, the mast and fork must be in the standard condition.
- When stacking or picking a load, the fork should be levelled. The operating speed should be slow down.
- The truck must be well maintained.



The standard condition when unloaded is that the mast is retracted completely, the fork raised about 30cm above the floor and tilted back completely.



The standard condition when loaded is that the mast is retracted completely, the fork raised about 10cm over the straddle leg and tilted back completely.

Chassis number position

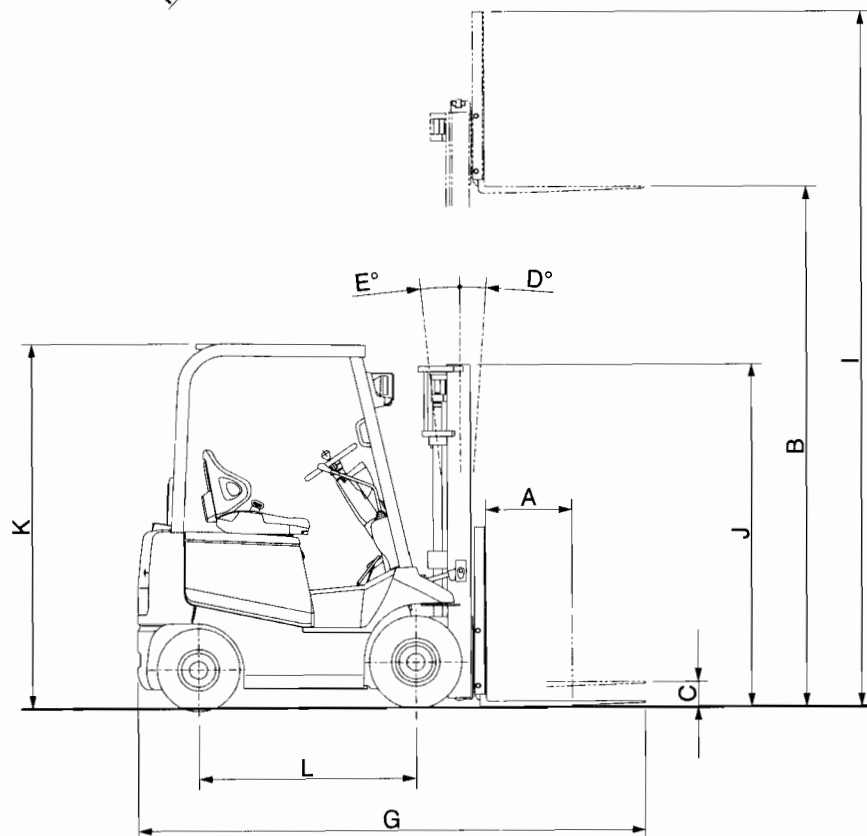
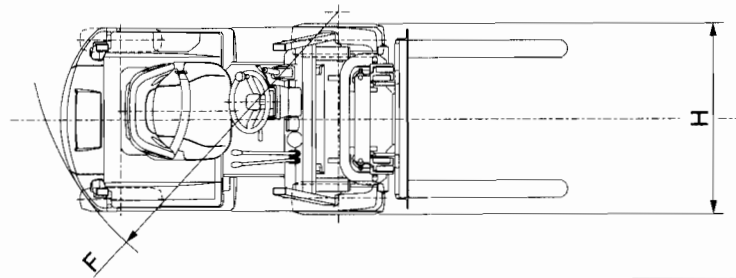
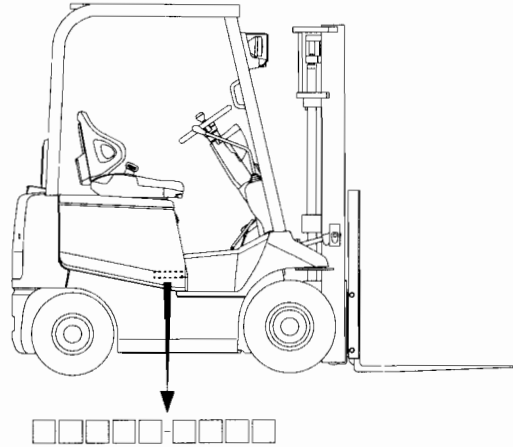

1) SPECIFICATIONS FOR STANDARD LIFT TRUCKS

MODELS			FB10P	FB14P	FB15P	FB18P	FB20P	FB25P	FB28P	FB30P
Capacity		kg	1000	1350	1500	1750	2000	2500	2750	3000
Load center	A	mm	500							
Lift height	B	mm	3000							
Free lift	C	mm	145				150		155	
Lift speed	Loaded	mm/s	370	340	320	310	280	260	250	320
	Unloaded		540				470		410	550
Tilt angle	Forward	°	6							
	Backward		12							
Travel speed	Loaded	Pneum. single	14.0			13.5	14.0	13.5	13.0	13.5
		Pneum. cushion	13.0			12.5	13.0	12.5	12.0	12.5
	Unloaded	Pneum. single	16.0			15.5	16.0	15.5	15.0	15.5
		Pneum. cushion	15.0			14.5	15.0	14.5	14.0	14.5
Min. turning radius	F	mm	1710			1725	1950	2005	2060	2240
Max. gradeability (Loaded) (5min)		%	22 %	20 %	19 %	17 %	19 %	16 %	14 %	16 %
Overall length	G	mm	3035			3080	3285	3345	3410	3580
Overall width	H	mm	1050		1090		1175		1180	
Overall height	Mast lifted	I	4000							
	Mast lowered	J	1980							
	Overhead guard	K	2110							
Wheel base	L	mm	1250				1400		1600	
Tread	Front wheel	mm	890		900		955		955	
	Rear wheel		900		900		945		980	
Road clearance		mm	110							
Service weight (w.o./Battery)		kg	2065	2200	2210	2385	2860	3305	3520	3530
Aisle width with pallet 1100x1100 mm		mm	3205			3225	3475	3530	3605	3815
Tyre	Front	Pneum. single	6.00-9-10PR		21 X 8-9-14PR		23 X 9-10-16PR		28X9-15-12PR	
		Pneum. cushion	6.00-9 Solid		21 X 8-9 Solid		23 X 9-10 Solid		28X9-15 Solid	
		Pneum. double	—		4.50-12-8PR		6.50-10-10PR		6.00-15-10PR	
	Rear	Pneum. single	5.00-8-8PR				18 X 7-8-14PR			
Pneum. cushion		5.00-8 Solid				18 X 7-8 Solid				
Control system (Travel/Hydraulic)			IGBT Inverter Control							
Electric motors	For traction	kw	9.0				10.0			
	For hydraulic		9.5				12.0			
	For power steering		0.4				0.5			
Battery	Std.	Ah/5HR	48V 330		48V 400		48V 450		48V 565	
	Option (1)		48V 400		48V 485		48V 545		48V 600	
	Option (2)		48V 485		48V 545		48V 565		—	
	Option (3)		48V 545		—		48V 600		—	
Charger (3 Phase 200/230V)			Automatic Stationary Charger							

*Subject to change without notice for improvement.

*Figures shown in the above specification table and unit with two stage full visibility mast.

2) SPECIFICATIONS FOR HIGH SPEED LIFT TRUCKS (U-Series)

MODELS			FB10P-U	FB14P-U	FB15P-U	FB18P-U	FB20P-U	FB25P-U
Capacity		kg	1000	1350	1500	1750	2000	2500
Load center	A	mm	500					
Lift height	B	mm	3000					
Free lift	C	mm	145				150	
Lift speed	Loaded	mm/s	470	440	420	380	360	340
	Unloaded		650				600	
Tilt angle	Forward	°	6					
	Backward		12					
Travel speed	Loaded	Pneum. single	16.0			15.5	15.5	15.0
		Pneum. cushion	15.0			14.5	14.5	14.0
	Unloaded	Pneum. single	18.0			17.5	17.5	17.0
		Pneum. cushion	17.0			16.5	16.5	16.0
Min. turning radius	F	mm	1710			1725	1950	2005
Max. gradeability (Loaded) (5min)		%	22 %	20 %	19 %	17 %	19 %	16 %
Overall length	G	mm	3035			3080	3285	3345
Overall width	H	mm	1050		1090		1175	
Overall height	Mast lifted	I	4000					
	Mast lowered	J	1980					
	Overhead guard	K	2110					
Wheel base	L	mm	1250				1400	
Tread	Front wheel	mm	890		900		955	
	Rear wheel		900		900		945	
Road clearance		mm	110					
Service weight (w.o./Battery)		kg	2065	2200	2210	2385	2860	3305
Aisle width with pallet 1100x1100 mm		mm	3205			3225	3475	3530
Tyre	Front	Pneum. single	6.00-9-10PR		21 X 8-9-14PR		23 X 9-10-16PR	
		Pneum. cushion	6.00-9 Solid		21 X 8-9 Solid		23 X 9-10 Solid	
		Pneum. double	—		4.50-12-8PR		6.50-10-10PR	
	Rear	Pneum. single	5.00-8-8PR				18 X 7-8-14PR	
Pneum. cushion		5.00-8 Solid				18 X 7-8 Solid		
Control system (Travel/Hydraulic)			IGBT Inverter Control					
Electric motors	For traction	kw	9.0				10.0	
	For hydraulic		12.0				13.5	
	For power steering		0.4				0.5	
Battery	Std.	Ah/5HR	48V 330		48V 400		48V 450	
	Option (1)		48V 400		48V 485		48V 545	
	Option (2)		48V 485		48V 545		48V 565	
	Option (3)		48V 545		—		48V 600	
Charger (3 Phase 200/230V)			Automatic Stationary Charger					

*Subject to change without notice for improvement.

*Figures shown in the above specification table and unit with two stage full visibility mast.

MODELS				FB35PJ-300
Performance	Capacity		kg	3500
	Load center		A mm	500
	Lift height		B mm	3000
	Free lift		C mm	150
	Lift speed	Loaded	mm/s	270
		Unloaded		460
	Tilt angle	Forward	°	6
		Backward		12
	Travel speed	Loaded	km/h	13.5
		Unloaded		15.5
Min. turning radius		F mm	2320	
Dimensions	Overall length		G mm	3645
	Overall width		H mm	1180
	Overall height	Mast lifted	mm	4000
		Mast lowered		2155
		Overhead guard		2245
	Wheel base		L mm	1600
	Service weight (w.o./Battery)		kg	4040
Tyre	Front	Pneum. single	28 X 9 – 15 – 14PR	
		Pneum. cushion	28 X 9 – 15 SOLID	
		Pneum. double	6.00 – 15 – 10PR	
	Rear	Pneum. single	6.50 – 10 – 12PR	
		Pneum. cushion	6.50 – 10 SOLID	
Control system (Travel/Hydraulic)			IGBT Inverter Control	
Electric motors	For traction		kw	10.0
	For hydraulic		kw	15.0
	For power steering		kw	0.7
Battery (72V)		Ah/5HR	450	
Charger (3 Phase 200/230V)			Automatic Stationary Charger	

*Subject to change without notice for improvement.

*Figures shown in the above specification table and unit with two stage full visibility mast.

The NICHYU electric forklift trucks for Cold Storage Application are designed to operate in the cold storage area.

The following CS type is available for -35°C storage area and FCS type is available for -55°C storage area.

○ **CS type**

The CS type is suitable for the operation in the -35°C class cold storage area.



The operating hours ratio of indoor and outdoor should be same level, and the continuous indoor operation is 30 minutes maximum.

○ **FCS type**

The FCS type is suitable for the operation in the -55°C class cold storage area.



The operating hours ratio of indoor and outdoor should be same level, and the continuous indoor operation is 30 minutes maximum.



In the -35°C class area, maximum one hour continuous operation is allowed, but operate outside of cold storage area for more than 30 minutes after then.



Do not leave the lift truck even CS type or FCS type in a cold storage area.

The electrical and mechanical parts are protected from rusting, corrosion and low temperature, but periodical cleaning, lubrication and maintenance are very important.

■ Protection from rust and corrosion

When going in and out of the cold storage area, the forklift truck is exposed to moisture which can cause rusting or corrosion.

To protect from the weather elements, a special coating and painting are applied to the CS and FCS type forklift trucks.

Also stainless bolts, nuts and washers are used on the front and rear axles for protection.

■ Protection from low temperature

1) Hydraulic oil and grease

Low viscosity oil and grease are required.

Refer to the following table.

2) Lubricating system

The grease nipples are provided on the major sliding parts.

Lubricate periodically to protect these parts from rusting and wearing.

3) Electrical parts

The control systems and switches are protected from rusting and freezing.



- Do not leave the forklift trucks in a cold storage area.
- Charging the battery shall be made in an area outside the cold storage area.

► Recommended oil for cold storage type

Manufacturer	Shell	ESSO
Hydraulic oil	Tellus T15	UNIVIS 43
Grease	Alvania grease RA	Beacon 325
Gear oil	Same as the standard lift truck	Same as the standard lift truck

■ *FB Series with sideshift attachment*



This operator's manual provides for the proper operation, easy maintenance and routine inspection of the sideshift attachment.

It can be difficult even for a trained operator to be able to align the forks each time to a pallet. If the load is not aligned correctly, it could cause the load to fall and create an unreasonable risk or injury to yourself and others. The sideshift attachment makes fork shifting easier by operating the lever. The sideshift attachment makes operating the forklift truck easier.

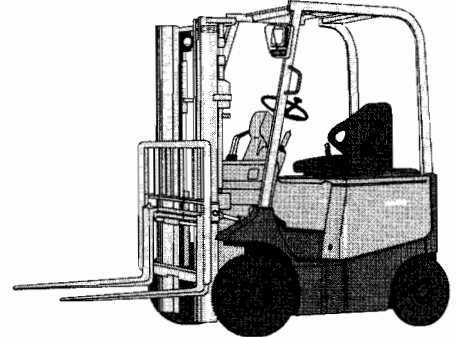

Features

- 1) Compact design
- 2) Movable load backrest extension
A movable load backrest extension is installed. The load is not damaged when shifting and tilting.
- 3) Shift indicator
The shift indicator is installed to indicate the shifting position.

■ Safe operation



Do not attempt to operate this attachment until you are thoroughly familiar with informations and safety precautions in this section.

► Information for safety operation



Do not overload. Observe allowable load capacity.

- Overload can cause the forklift truck to tip over or the load to fall.

The forklift truck with a sideshift attachment has a lower capacity in comparison to the standard forklift truck without sideshift attachment.

Prior to operation, check the weight of the load and the center of gravity.

Observe the load chart on the forklift truck.

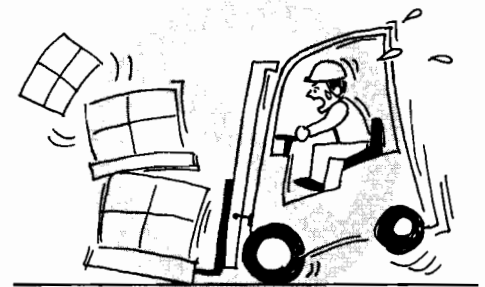

- Make sure the forks are inserted in the correct position.
- Do not pick up an off-center load.

- Picking up an off-centered load can cause the forklift truck to tip over or the load to fall.

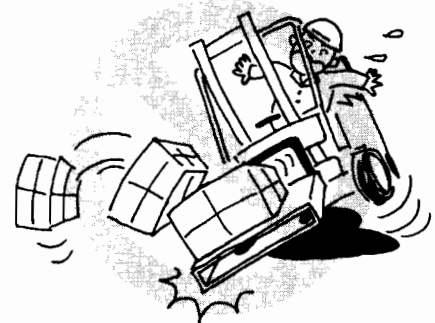

Adjust the shift indicator to the neutral position before traveling.

- Do not travel while shifting positions as it can cause the forklift truck to tip over.

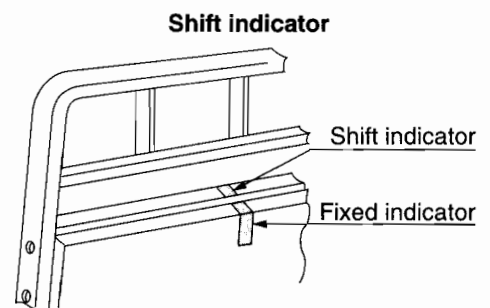

When the shift indicator adjusts to the fixed indicator, it is the neutral position.

Part name and function

Parts name

Hydraulic lever

- ① Lift lever
- ② Tilt lever
- ③ Sideshift lever

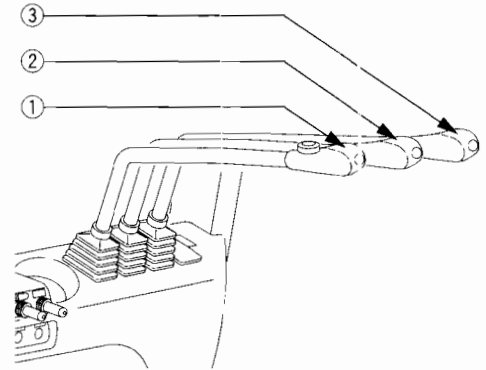

Sideshift fork attachment

- ① Load backrest
- ② Sideshift cylinder
- ③ Sideshift carriage
- ④ Fork

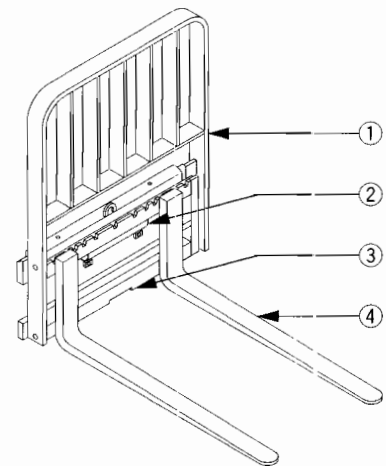

Function of sideshift

- When pulling the sideshift lever, (toward B) the forks move toward B.
- When pushing the sideshift lever, (toward A) the forks move toward A.

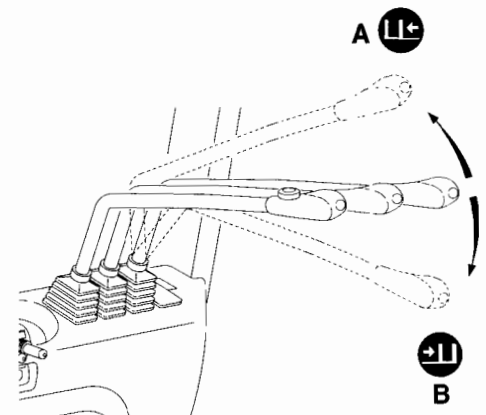

Operate all hydraulic levers from the operator's seat.



Control the sideshift speed by the stroke of sideshift lever.

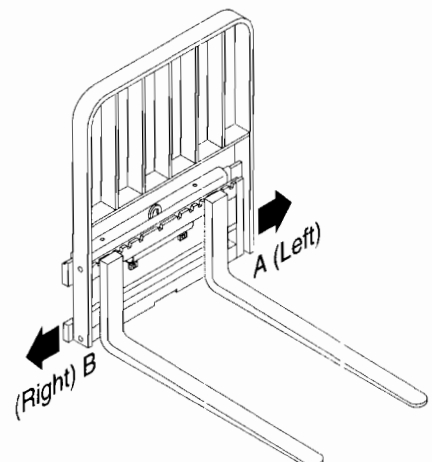

Materials handling

When stacking or picking a load with using the sideshift attachment, observe the following procedures.

Stacking operation



Check the following items before starting operation of the forklift truck.

- Make sure there is no load falling or damage of load at loading area.
- Make sure there is no foreign object in the stacking area.

When stacking a load, observe the following procedures.

- ① Reduce travel speed and stop in front of the stacking area.
- ② Make sure it is safe around the stacking area.
- ③ Face the truck to the stacking position correctly.
- ④ Adjust the pallet position by using sideshift.

- ⑤ Tilt the forks to horizontal position and raise the forks above the stacking position.

- ⑥ Adjust the stacking position by using the sideshift again.

- ⑦ Extend the mast and stop when the load is just above the stacking position.

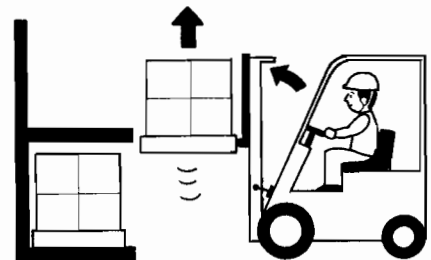
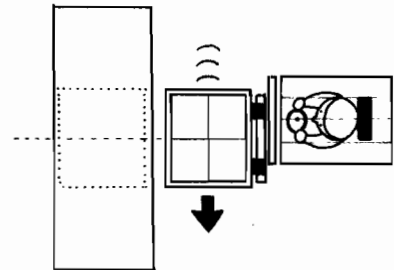

- ⑧ Lower the forks slowly making sure the load is on in the correct position.



When the load is not aligned at the front or the rear, adjust such non-alignment according to the following procedures:

- 1) Lower the forks until the load is placed on the shelf, and the forks become free.
- 2) Retract the mast backward about 1/4 length of the forks
- 3) Lift (50-100mm) forks again and extend to align the load. Lower the load slowly in the proper stacking position.

- ⑨ Slowly retract the mast while not catching the forks on the pallet or load.

- ⑩ Make sure the tips of the forks are not touching the load or pallet, and lower the forks to the position for traveling (150-200mm above the straddle legs.)

► Picking operation

When picking a load, observe the following procedures:

- ① Reduce your travel speed and stop in front of the load. (about 300mm between the load and the tips of the forks.)
- ② Correctly face the forklift truck to the load.
- ③ Adjust the fork position by using sideshift.

- ④ Make sure the load is stable and not loose.
- ⑤ Tilt the mast to horizontal position and raise the forks to the inserting position of the load.

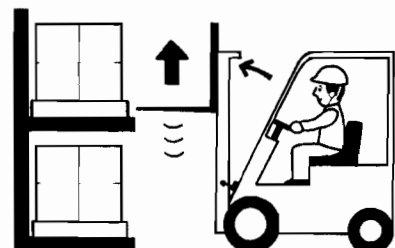
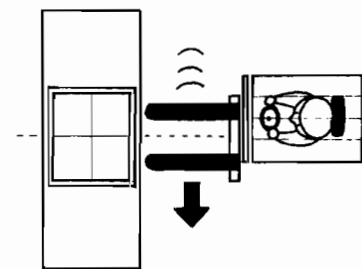
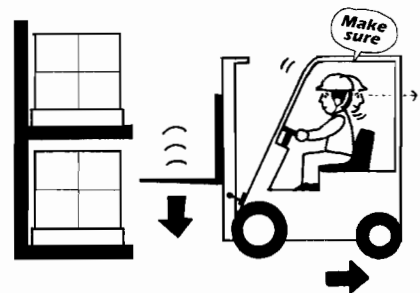

- ⑥ Adjust the stacking position by using sideshift again.
- ⑦ Slowly extend the mast until the forks are fully inserted into the pallet.



When it is difficult to fully insert the forks into the pallet:

- 1) Insert about 3/4 length of the forks and lift up the pallet a little (50mm-100mm).
- 2) Pull the pallet out about 100-200mm.
- 3) Lower the pallet again on the shelf and fully insert the forks into the pallet.

- ⑧ After inserting the forks, raise the pallet (50-100mm).
- ⑨ Slowly retract the mast until the load is placed down.

- ⑩ Make sure the load is completely out from the shelf. Lower the load to the traveling position. (150-200mm above the straddle legs.)

⑪ Adjust the load position to the forklift truck center by using the shift indicator.

- ⑫ Tilt the forks up.

- ⑬ Carry the load to its destination.

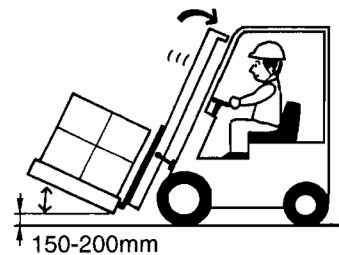
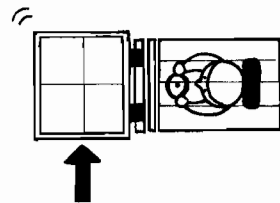
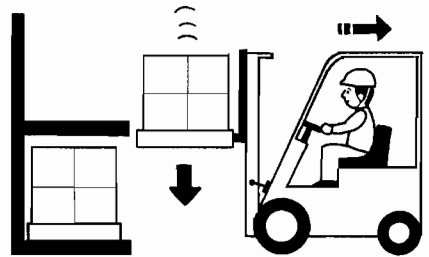
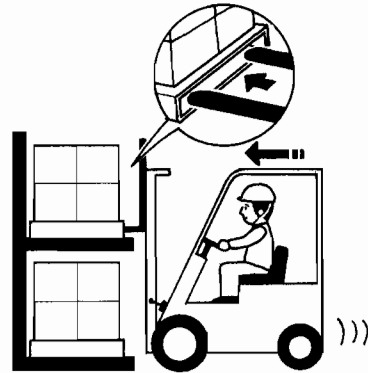

■ Periodical inspection and service

The proper inspection and maintenance prevent from unexpected breakdown and prolong the lifetime of the forklift truck. The periodical inspection should be planned for comfortable and safe operation.

- When adjustments or replacement parts are necessary, contact NICHYU's qualified facility.
- Use only NICHYU genuine parts for replacement.
- Lubricate after wiping the old grease and dust off from nipples and fittings by a brush or rug.



Refer to the Operator's Manual of the forklift truck for details of the inspection and maintenance of the forklift truck.



▶ Daily inspection

For the safe operation, the daily inspection of the forklift truck should be carried out before starting operation. If any abnormalities are found, the forklift truck shall be maintained and repaired.

Item	Detail of inspection
Upper hook	Make sure the upper hook of the fork is hung on the carriage completely.
Lower hook	Make sure the lower hook is caught enough.
Bolts	Mounting bolts of the load backrest and the lower hook are tightened securely.
Cylinder, Hoses	Any oil leaks

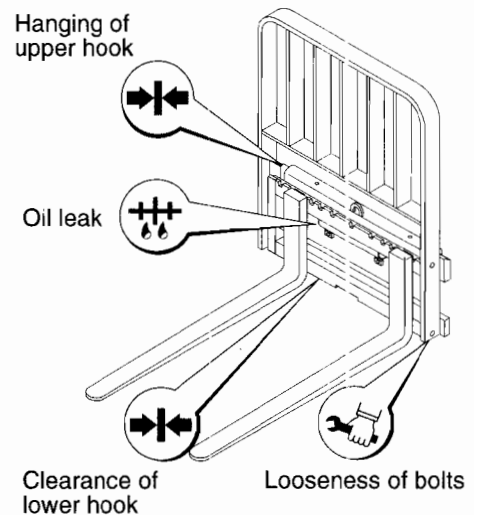

► **Periodical inspection of every 100-hour**

In every 100-hour or every chance to repair, inspect the following points. If any abnormalities are found, repair them immediately.

Item	Detail of inspection
Upper hook	Make sure the upper hook of the fork is hung on the carriage completely.
Lower hook	Make sure the clearance (0 to 2 mm)
Bolts	Mounting bolts of the load backrest and the lower hook are tightened securely.
Cylinder, Hoses	Any oil leaks

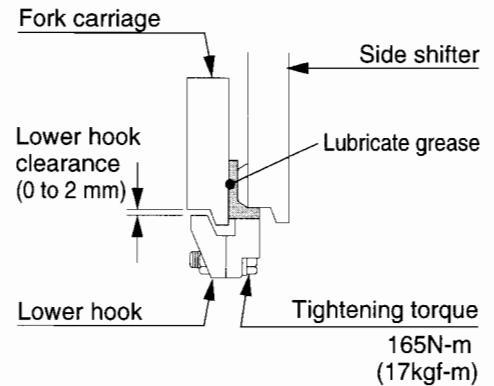

► **Periodical inspection of every 300-hour**

In every 300-hour operation, the following points should be inspect additionally to the 100-hour inspection points. If any abnormalities are found, repair them immediately.

Item	Detail of inspection
Upper and lower bearings	Lubrication
Bolts	Check torque and additional tightening

► **Periodical inspection of every 1000-hour**

In every 1000-hour operation, the following points should be inspect additionally to the 100-hour and 300-hour inspection points. If any abnormalities are found, repair them immediately.

Item	Detail of inspection
Upper and lower bearings	If the thickness is less than 3 mm, replace both upper and lower bearings.
Hook of the fork bar and fork	Check wearing condition

► **Periodical inspection of every 2000-hour**

In every 2000-hour operation, the following parts are recommended to replace additionally to the 100-hour, 300-hour and 1000-hour inspection points.

Replacing part
Upper and lower bearings
Cylinder seal kit

■ *Periodical replacing parts*

Periodical inspection and maintenance are very important to keep your forklift truck in good condition.

These parts in the table are also very important for safe operation. Therefore, NICHYU recommends that you replace these parts each period even if their appearances are good. Use genuine NICHYU parts for replacement. (The periodical replacement is not covered by warranty.)

	Periodical replacement parts	Replacement time
1	Slide shoe	1 year
2	H.P. hose	2 years

14

FINGER TIP LEVER



This operators manual provides the proper operation about the finger tip (option).

Operating equipment

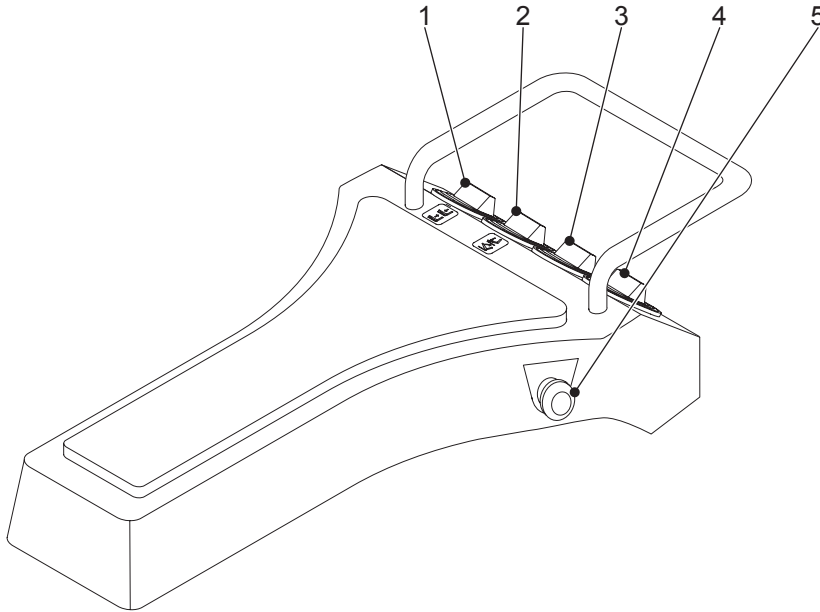

1. Lift lever
2. Tilt lever
3. Side shift lever
4. Attachment
5. Emergency switch



Operate all hydraulic levers from the operator's seat.

1. Lift lever

Lifting up forks : Pull the lift lever forward.
Lowering forks : Push the lift lever backward.



Lifting and lowering speed can be adjusted by operating angle of the lift lever.



Do not stop lifting or lowering suddenly.

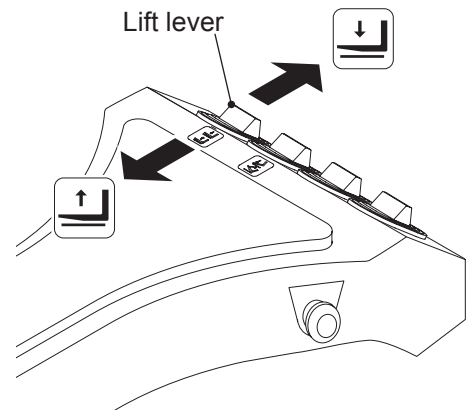

FINGER TIP LEVER

2. Tilt lever

Tilting up forks : Pull the tilt lever forward.

Tilting down forks : Push the tilt lever backward.



Tilt speed can be adjusted by operating angle of the tilt lever.

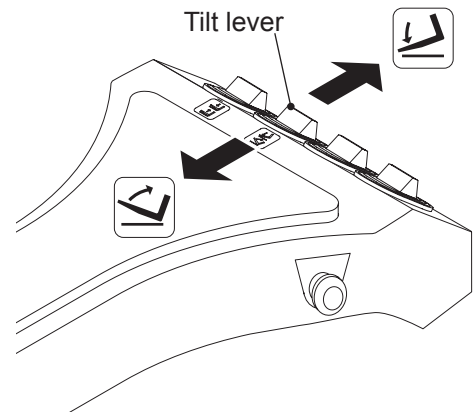

3. Side shift lever

Shifting to left : Pull the shift lever forward.

Shifting to right : Push the shift lever backward.



Shifting speed can be adjusted by operating angle of the side shift lever.

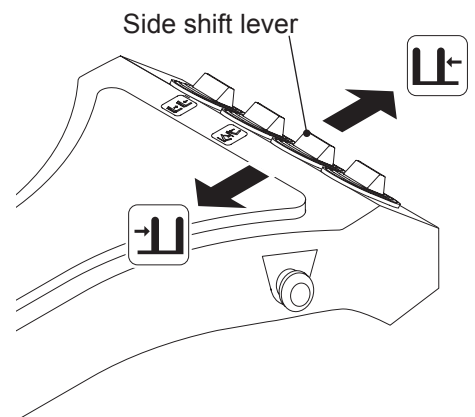

4. Attachment (Option)

Operation is depended on your attachment.

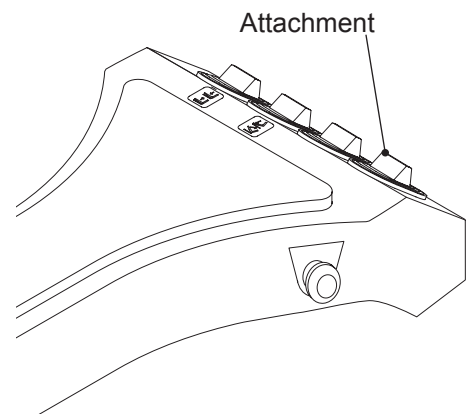

5. Emergency switch

In the emergency case, press the emergency switch. The power supply for hydraulic operation is shut off. By turning the knob to clockwise, the truck can be powered on again.

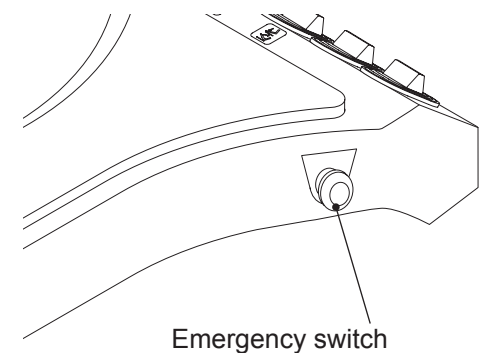

Preparation of start

- 1) Check the directional lever is in the neutral position and the parking brake is applied.

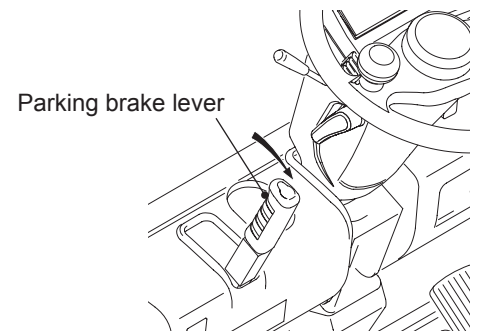
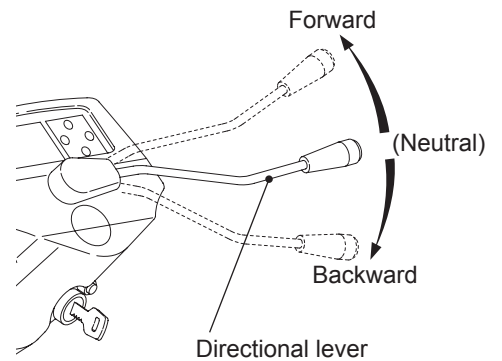

- 2) Turn on the key switch

Grasp the steering wheel knob and then turn on the key switch.

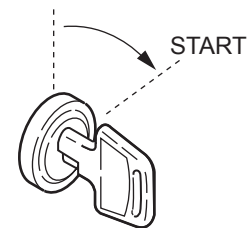

- 3) Tilting back the mast ass'y.

- Raise the forks about 150 to 200mm from the floor by the lift lever.
- Tilt back the mast ass'y by the tilt lever.

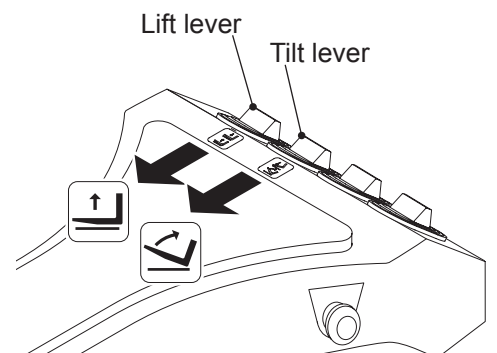

Automatic power off function :

- Suspending the travel and hydraulic operation for 15 minutes, electric circuit is turned off automatically. Turn the key switch into the [START] position to turn the power on again.

4) Operation of the directional lever

Operate the directional lever to the moving direction.

Forward : Push the lever forward.

Backward : Pull the lever backward.

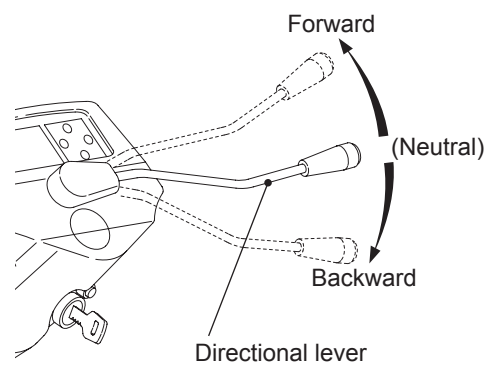
**5) Release the parking brake**

Depress the brake pedal.

Push the parking brake lever forward fully to release the parking brake.

Grasp the steering wheel knob by the left hand, put the right hand lightly on the steering wheel.

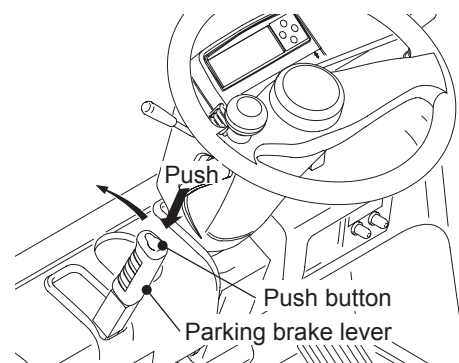

With additions from:

FINGER TIP

OPERATOR'S MANUAL

Pub No. OP-09-004

First printing : December 2009

Issued by : Nippon Yusoki Co., Ltd.

Overseas Division

Reproduction prohibited

First printing : December 2007

Second edition : July 2008

Issued by : Nippon Yusoki Co., Ltd.

Overseas Division

NICHIYU

Nippon Yusoki Co., Ltd.

1-1, 2-Chome, Higashikotari, Nagaokakyo-shi, Kyoto 617-8585 JAPAN

Tel: +81-(0)75-956-8622 Fax: +81-(0)75-955-0480 URL: <http://www.nichiyunet.co.jp/en>

Printed in Japan
Pub No. OP-03-019-R1
300/0807
Copy rights