

**Forklift truck with counterweight and operator seat, ideal for special load handling over long distances**



---

The Modus FS ac forklift trucks with counterweight, operator seat and tilting forks are ideal for special load handling over long distances. Lateral steering wheel for optimal visibility on aisles, in both directions. Rugged structure for maximum reliability in extreme conditions. Characterised by compact size and high manoeuvrability, suitable for applications in all sectors. For lifting between 1,610 mm and 4,610 mm.

---

### **Frame**

Made of bended sheet metal to minimise any tensions induced by welds, ensuring maximum mechanical resistance over time. The battery compartment cover is hinged, facilitating battery top-up and daily and periodical maintenance operations. Particular attention was paid to simplify the access to mechanical parts so as to minimise the routine maintenance costs.

### **Masts**

The OMG masts are made of cold extruded profiles, ensuring high resistance to bending and twisting. The lift cylinders are installed outside of the mast profiles and the chains are protected to ensure perfect visibility and

maximum safety for the operator. Available in simplex, duplex and triplex version with wide free lift. The mast comes with standard tilt function that facilitates load picking and storage operations.

### **Hydraulic functions**

The 4kW powerful and silent lift motor with high torque ratio ensures high performance with low power consumption. The pump is highly efficient and very quiet. It comes with tilting system installed on the mast and standard built-in shifter.

## Drive

Powerful and reliable AC traction motor, capable of meeting even the most demanding requests in terms of performance, under any conditions.

## Electronic system

The machine is fitted with AC control with energy recovery, that can be enabled by:

- releasing the accelerator pedal;

- reversing the running direction

From this control, the operator can manage all truck's functions and carry out unlimited adjustments for performance optimisation, adapting the machine to any application, while ensuring silent operation and low power consumption at the same time.

---

## Comfort when picking and storing loads

The configuration with four support points provides optimal lateral stability, ensuring maximum safety and comfort during load picking and storage. The lifting, lowering and shifting levers ensure precise and smooth load lifting and lowering. The hydraulic motor with fluid adjustment system reduces the noise, ensuring at the same time smooth and precise load lifting. Enhanced lifting and lowering speed for faster operations. Side cylinders fitted with silent blocks to prevent any kickbacks that might affect the stability of the load during forks lowering.



---

## Operator's compartment

- comfortable adjustable seat;
- non-slip footrest;
- small steering wheel;
- low step height for easy access.

---

## Operation ensured in any conditions

The self-levelling axle ensure maximum grip on all surfaces, even when the truck is loaded.



## Accessories and special features

total free lift for duplex column	■	access keypad with pin code	■
total free lift for triplex column	■	anti roll-back device	■
protection for cold storage	■	electronic speed control	■
supertrack drive wheel	■	electronic braking system	■
polyurethane drive wheel	■	electromagnetic parking brake	■
servo-assisted electric steering	■	voltmeter-timer, auto-lock function when 80% of the battery capacity is discharged	■
lateral battery extraction system	■	3rd hydraulic function with built-in shifter	■
single roller for lateral battery extraction	■	tilt function on mast	■
double lateral battery extraction roller with wheels	■	multifunction monojoystick	■

standard ■

optional ■

Standard masts							Capacities:	
Description		Lowered mast height	Forks lifting stroke	Total lift	Extended mast height	Free lift	Mast tilting system	(t) c=600 mm
		h <sub>1</sub>	h <sub>3</sub>	h <sub>3</sub> +h <sub>13</sub>	h <sub>4</sub>	h <sub>2</sub>	/	
Simplex	mm	2,130	1,610	1,650	2,130	1,565	1 / 4	1.3
Duplex	mm	2,135	3,060	3,100	3,675	1,275 *	1 / 4	1.3
	mm	2,385	3,560	3,600	4,175	1,525 *	1 / 4	1.1
Triplex GAL	mm	1,990	4,160	4,200	4,780	1,275	1 / 4	1.0
	mm	2,140	4,610	4,610	5,225	1,375	1 / 4	0.7

\* optional

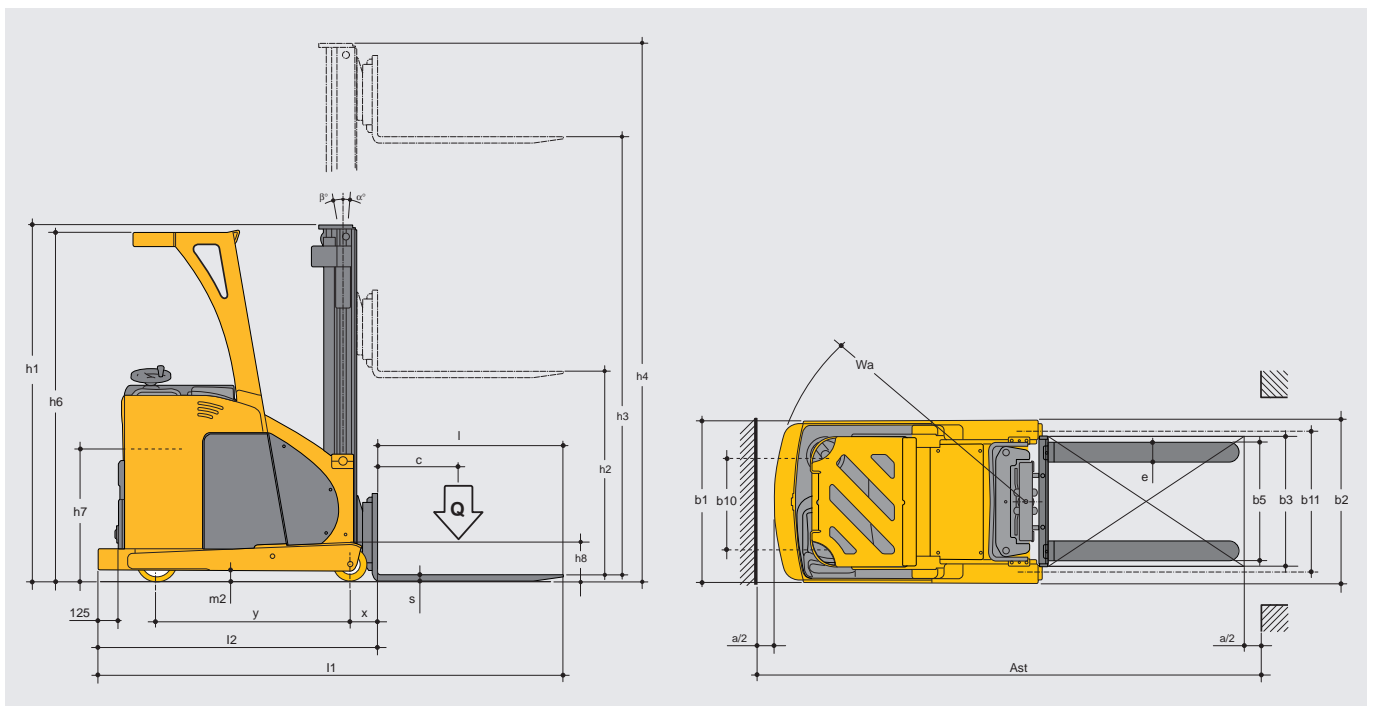

Characteristics	1.1	Manufacturer			OMG S.r.l. Single member company	
	1.2	Model			Modus FS ac	
	1.3	Operation			Electric	
	1.4	Operator position			Ride-on	
	1.5	Capacity	Q	t	1.3	
	1.6	Load centre of gravity	c	mm	600	
	1.8	Load distance	x	mm	170	
	1.9	Wheel centre distance	y	mm	1,200	
	Weights	2.1	Truck weight incl. battery (see line 6.5)			kg
2.3		Weight on axis without front / rear load			kg	1,140 / 1,640
2.4		Weight on axis with front / rear load and extended mast			kg	3,240 / 838
2.5		Weight on axis with front / rear load and retracted mast			kg	
Wheels Frame	3.1	Wheels and tyres			polyurethane	
	3.2	Front wheel size		mm	245 / 150	
	3.3	Rear wheels size		mm	200	
	3.5	Number of front / rear wheels (x = drive)		no.	1x + 1 / 2	
	3.6	Front track	b10	mm	685	
	3.7	Rear track	b11	mm	850	
	Base dimensions	4.1	Mast/forks support plate inclination, forward/backward	/	°	1 / 3
4.2		Lowered mast height	h1	mm	2,140	
4.3		Free lift	h2	mm	1,630	
4.4		Forks lifting stroke	h3	mm	4,610	
4.5		Extended mast height	h4	mm	5,225	
4.7		Upper edge overhead guard height (cabin)	h6	mm	2,100	
4.8		Seat height / Platform height	h7	mm	820	
4.10		Forks height	h8	mm	230	
4.19		Overall length	l1	mm	2,882	
4.20		Length including forks heel	l2	mm	1,732	
4.21		Overall width	b1/b2	mm	980	
4.22		Forks size	s/e/l	mm	35 / 120 / 1,150	
4.23		Forks support plate ISO 2328, class/type A, B			Fem 2A	
4.24		Forks support plate width	b3	mm	840	
4.25		Width over forks	b5	mm	750	
4.31		Clearance under the mast with load	m1	mm		
4.32		Clearance at mid stroke	m2	mm	75	
4.33		Working aisle width with 1000 x 1200 transversal pallet	Ast	mm		
4.34		Working aisle width with 800 x 1200 longitudinal pallet	Ast	mm	3,132	
4.35		Turning radius	Wa	mm	1,745	
4.37	Length including support forks	l7	mm			
Performance	5.1	Speed with / without load		km/h	8 / 10	
	5.2	Lifting speed with / without load		m/s	0.16 / 0.34	
	5.3	Lowering speed with/without load		m/s	0.30 / 0.28	
	5.8	Max. feasible gradient with / without load		%	6 / 10	
	5.9	Acceleration with / without load		s		
	5.10	Service brake			electromagnetic	
Electric motors	6.1	Traction motor, performance with S2 60 min		kW	2.6	
	6.2	Lift motor, performance with S3 15%		kW	4	
	6.3	Battery as per DIN 43531 / 35 / 36 A, B, C, no			24 / 500	
	6.4	K5 battery voltage, nominal capacity		V/Ah	24 / 500	
	6.5	Battery weight		kg	370	
	6.6	Power consumption as per VDI cycle		kW/h		
Miscellaneous	8.1	Type of electronic system			ac	
	8.2	Equipment operating pressure		bar	160	
	8.3	Oil flow rate for equipment		l/min		
	8.4	Noise threshold as per EN 12 053		dB(A)	< 70	
					* optional	

Technical data sheet referring to pallet truck in standard version; data determined in compliance with VDI 2198. These values may differ if your product is fitted with other types of wheels and tires, supports and accessories. All data and images herein are indicative, OMG S.r.l. Single member company reserves the right to modify the documentation without prior notice.