

Rugged, fast and easy to use electric forklift trucks.



The 716-720 P ac models are ride-on forklift trucks that combine the stability and the precision of a column forklift truck with the speed and convenience of a truck with rider platform. Equipped with powerful engines for high performance and fast travel speed, suitable for horizontal loads handling over long distances. The high-capacity battery ensures long battery life. High visibility mast with lift capacity between 1,560 mm and 5,310 mm.

Frame

Made of bended sheet metal to minimise any tensions induced by welds, ensuring maximum stability and best mechanical resistance under any conditions of transport and storage. The configuration with four support points provides maximum stability. The simple pivoting wheel adjustment system helps maintaining the same grip level, compensating for any wear-out of the drive wheel. The highly visible masts and the lateral tiller ensure optimal visibility for load storage, picking and transport. The battery compartment cover is hinged, facilitating battery top-up and daily and periodical maintenance operations. Particular attention was paid to simplify the access to mechanical parts so as to minimise the routine maintenance costs.

Masts

The OMG masts are made of cold extruded profiles, ensuring high resistance to bending and twisting. The lift cylinders are installed outside of the mast profiles and the chains are protected to ensure perfect visibility and maximum safety. Available in simplex, duplex and triplex version with wide free lift.

Hydraulic functions

The 3kW powerful and silent lift motor with high torque ration offers high performance with low power consumption. With highly efficient, silent pumps. The mini joystick installed on the tiller (finger touch) allows the operator to lift and lower the forks without releasing the tiller.

Drive

Powerful and reliable AC traction motor, capable of meeting even the most demanding requests in terms of performance, under any conditions. Travel speed controlled directly by the throttle installed on the tiller. Standard servo-assisted steering for simple and precise driving.

Braking system

There are three braking systems in this range:

- braking by reversing the running direction and releasing the throttle (service braking that can be adjusted from the control panel);
- emergency braking that takes place automatically if the tiller is suddenly released or lowered (electromagnetic brake);

- parking brake.

consumption at the same time.

Electronic system

The machine are fitted with AC control with power recovery during braking, when the running direction is reversed and the control throttle is released. From this control, the operator can manage all truck's functions and carry out unlimited adjustments for performance optimisation, adapting the machine to any application, while ensuring silent operation and low power

Models 716 – 720 P ac are fitted with 24V 375Ah traction battery. Lateral battery extraction system supplied as standard, ideal on multiple shifts.



The configuration with four support points provides optimal stability, ensuring maximum safety and comfort during load picking and storage. The mini joystick (finger touch) allows the operator to control the truck by simply moving his finger along the tiller, ensuring precise and smooth load lifting and lowering, without taking his hands off the tiller. The hydraulic motor with fluid adjustment system reduces the noise, ensuring at the same time smooth and precise load lifting. Enhanced lifting and lowering speed for faster operations. Side cylinders fitted with silent blocks (standard) to prevent any kickbacks that might affect the stability of the load during forks lowering.



Driving comfort

- The central operator workstation located inside the chassis protects the operator while offering him excellent visibility
- Comfortable operator platform with cushioned footrest
- Strong and robust armrests covered in polyurethane
- Spring lever for lateral armrests unlocking, allowing you to switch from a ride-on truck to a walk behind truck in just a few seconds



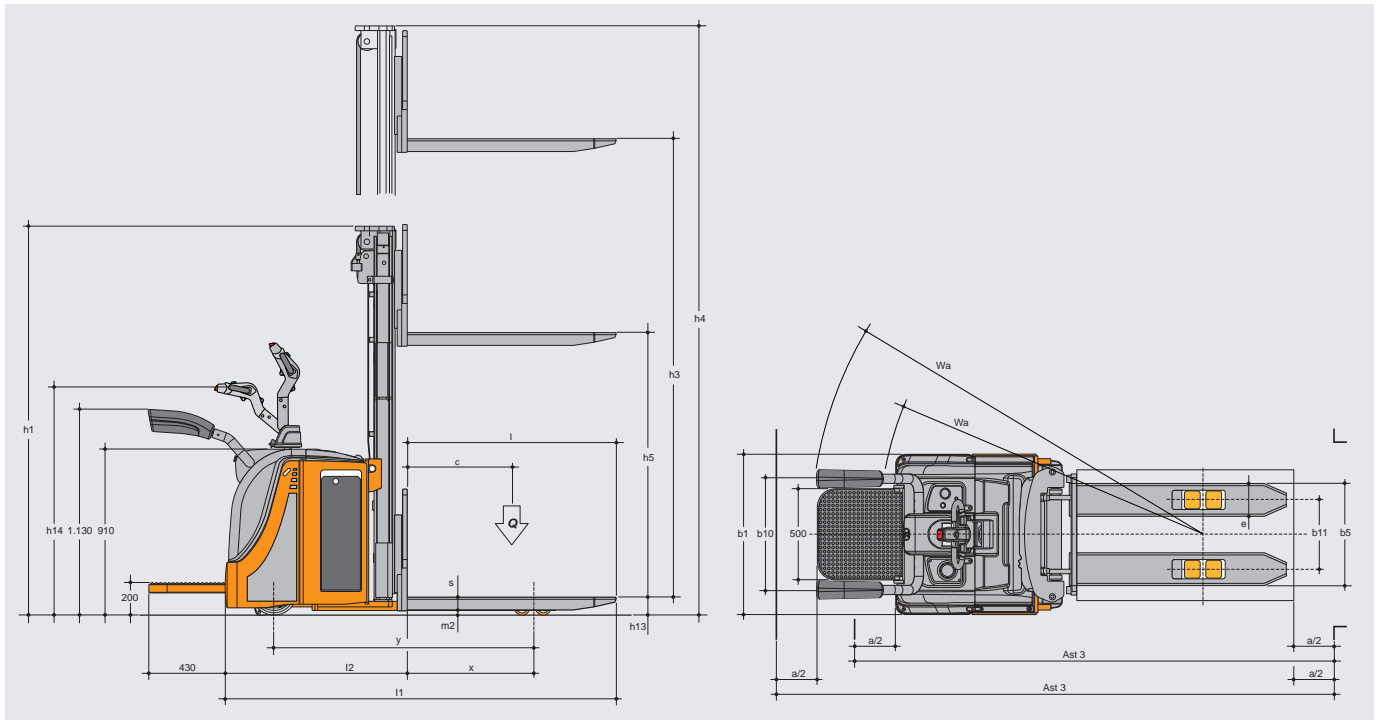

Accessories and special features

total free lift for duplex column	<input type="checkbox"/>	double lateral battery extraction roller with wheels	<input type="checkbox"/>
total free lift for triplex column	<input type="checkbox"/>	access keypad with pin code	<input type="checkbox"/>
protection for cold storage	<input type="checkbox"/>	anti roll-back device	<input type="checkbox"/>
supertrack drive wheel	<input type="checkbox"/>	electronic speed control	<input type="checkbox"/>
polyurethane drive wheel	<input type="checkbox"/>	electronic braking system	<input type="checkbox"/>
double load rollers	<input type="checkbox"/>	electromagnetic parking brake	<input type="checkbox"/>
low speed push-button with tiller in vertical position	<input type="checkbox"/>	voltmeter-timer, auto-lock function when 80% of the battery capacity is discharged	<input type="checkbox"/>
servo-assisted tiller	<input type="checkbox"/>	Fem II plate with forks with adjustable angle	<input type="checkbox"/>
lateral battery extraction system	<input type="checkbox"/>	mini-joystick (finger touch) for lifting and lowering	<input type="checkbox"/>
roller for lateral battery extraction	<input type="checkbox"/>	24V 35A current rectifier on-board	<input type="checkbox"/>
		standard <input type="checkbox"/>	optional <input type="checkbox"/>

		Standard masts				716 P ac	720 P ac
Description	Lowered mast height	Forks stroke	Total lifting	Extended mast height	Free lift	Capacity (t)	Capacity (t)
	h1	h3	h3+h13	h4	h2	(t) c=600 mm	(t) c=600 mm
Simplex	mm 2,080	1,560	1,650	2,245	1,560	1.6	2.0
Duplex	mm 1,955	2,710	2,800	3,395	1,410 *	1.6	2.0
	mm 2,105	3,010	3,100	3,395	1,560 *	1.45	1.8
	mm 2,360	3,510	3,600	4,195	1,810*	1.25	1.6
Triplex GAL	mm 1,960	4,110	4,200	4,795	1,410	1.0	1.4
	mm 2,110	4,560	4,610	5,245	1,560	0.85	1.1
	mm 2,360	5,310	5,400	6,000	1,810	0.5	0.7

* optional

Characteristics	1.1	Manufacturer			OMG S.r.l. Single member company		
	1.2	Model			716 P ac	720 P ac	
		Execution					
	1.3	Operation			Electric	Electric	
	1.4	Operator position			At ground level / Ride-on	At ground level / Ride-on	
	1.5	Capacity	Q	t	1.6	2.0	
		Mast lift capacity	Q	t	/	/	
		Forks lift capacity	Q	t	/	/	
		Forks + mast lift capacity	Q	t	/	/	
	1.6	Load centre of gravity	c	mm	600	600	
1.8	Load distance	x	mm	692	672		
1.9	Wheel centre distance	y	mm	1.425	1.446		
Weights	2.1	Truck weight incl. battery (see line 6.5)			kg	1.320	1.360
	2.2	Weight on axis with front / rear load			kg	1.020 / 1.900	1.060 / 2.500
	2.3	Weight on axis without front / rear load			kg	880 / 440	930 / 470
Wheels Frame	3.1	Wheels and tyres				polyurethane	polyurethane
	3.2	Front wheel size		mm	85	85	
	3.3	Rear wheels size		mm	245	245	
	3.4	Stabiliser wheels size		mm	150	150	
	3.5	Number of front / rear wheels (x = drive)		no.	1x + 1 / 4	1x + 1 / 4	
	3.6	Front track	b10	mm	535	535	
	3.7	Rear track	b11	mm	380	380	
Base dimensions	4.2	Lowered mast height	h1	mm	2.360	2.360	
	4.3	Free lift	h2	mm	1.810	1.810	
	4.4	Forks lifting stroke	h3	mm	3.510	3.510	
	4.5	Extended mast height	h4	mm	4.195	4.195	
	4.6	Initial lift	h5	mm	/	/	
	4.9	Tiller height in min. /max. driving position	h14	mm			
	4.15	Forks lowered height	h13	mm	90	90	
	4.19	Overall length	l1	mm	2.153 / 2.583	2.183 / 2.613	
	4.20	Length including forks heel	l2	m	1.003	1.033	
	4.21	Overall width	b1/ b2	mm	880	880	
	4.22	Forks size	s/e/l	mm	70 / 180 / 1.150	70 / 180 / 1.150	
	4.25	Width over forks	b5	mm	560	570	
	4.32	Clearance at mid stroke	m2	mm	15	15	
	4.33	Working aisle width with 1000 x 1200 transversal pallet	Ast	mm			
	4.34	Working aisle width with 800 x 1200 longitudinal pallet	Ast	mm	2.710 / 2.990	2.790 / 3.040	
4.35	Turning radius	Wa	mm	1.865 / 2.145	1.886 / 2.176		
Performance	5.1	Speed with / without load		km/h	8.2 / 8.5	8.2 / 8.5	
	5.2	Lifting speed with / without load		m/s	0.14 / 0.18	0.14 / 0.18	
	5.3	Lowering speed with/without load		m/s	0.38 / 0.30	0.38 / 0.30	
	5.8	Max. feasible gradient with / without load		%	7 / 15	7 / 15	
	5.10	Service brake			Electromagnetic	Electromagnetic	
Electric motors	6.1	Traction motor, 60 min performance with S2		kW	2.6	2.6	
	6.2	Lift motor, 15% performance with S3		kW	3	3	
	6.3	Battery as per DIN 43531 / 35 / 36 A, B, C, no			43531 A	43531 A	
	6.4	K5 battery voltage, nominal capacity	V/Ah		24 / 270 - 345* - 375*	24 / 345 - 375	
	6.5	Battery weight	kg		230	230	
	6.6	Power consumption as per VDI cycle	kW/h		1.25	1.25	
Miscellaneous	8.1	Type of electronic system			ac	ac	
	8.4	Noise threshold as per EN 12 053		dB(A)	< 70	< 70	
						*optional	

Technical data sheet referring to pallet truck in standard version; data determined in compliance with VDI 2198. These values may differ if your product is fitted with other types of wheels and tires, supports and accessories. All data and images herein are indicative, OMG S.r.l. Single member company reserves the right to modify the documentation without prior notice.